

**MAXIMUM PRODUCT LOAD RATING: 150 kg** 

**IMPORTANT:**

- **LOAD = WEIGHT OF PLATFORM or BARS + MOUNTING SYSTEM + ACCESSORIES + CARGO**
- **PLEASE REFER TO VEHICLE MANUFACTURER SPECIFICATIONS FOR MAX ROOF LOAD CAPACITY OF VEHICLE. THE LOWEST LOAD RATING APPLIES.**
- **OFFROAD RATING: SCAN QR CODE FOR LOCKNLOAD LOAD RATING GUIDE. REDUCTIONS MAY APPLY.**



## FIRST TIME INSTALLATION

- Please read instructions carefully before installation.
- Check the contents of kit. Each LockNLoad RuggedLine has the last four digits of the kit's part number lasered in. Contact your YAKIMA dealer if any parts appear missing, incorrect or damaged.
- Clean your roof thoroughly prior to fitting the LockNLoad RuggedLine.
- Place these instructions in the vehicle's glove box after installation is complete.



**TOOLS REQUIRED:**

- 13 mm Spanner
- Trim Removal Tool
- Phillips Head Screwdriver
- T30 Torx Key
- Drill
- 5 mm Drill Stop
- Dremel

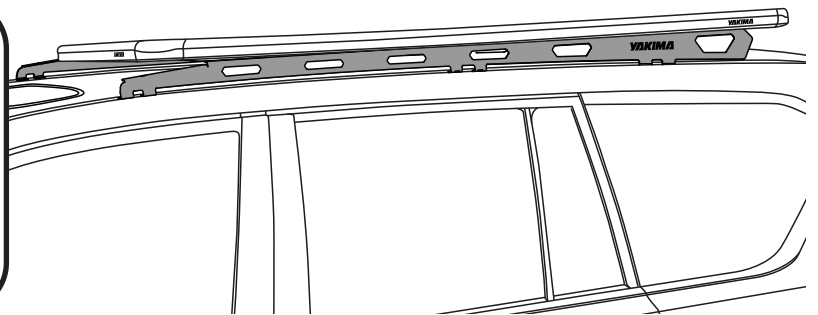

## KIT CONTENTS

ITEM	COMPONENT	QTY	ITEM	COMPONENT	QTY
1.	Patrol Y62 Short RuggedLine RH 1005	x1	7.	M8 Nyloc Nut	x6
2.	Patrol Y62 Short RuggedLine LH 1005	x1	8.	Foam Adhesive	x12
3.	Pivot Bracket	x6	9.	Silicone Sealant	x1
4.	M8 x 20 mm Socket Head Cap Screw	x18	10.	4 mm T-Handle Ball End Allen Key	x1
5.	M8 Washer	x24	11.	6 mm T-Handle Ball End Allen Key	x1
6.	M8 Spring Washer	x12	12.	Template Sticker Set	x1



**PLATFORM & COMPONENTS SOLD SEPARATELY  
RECOMMENDED PLATFORM SIZE IS 'C' (9820339)**

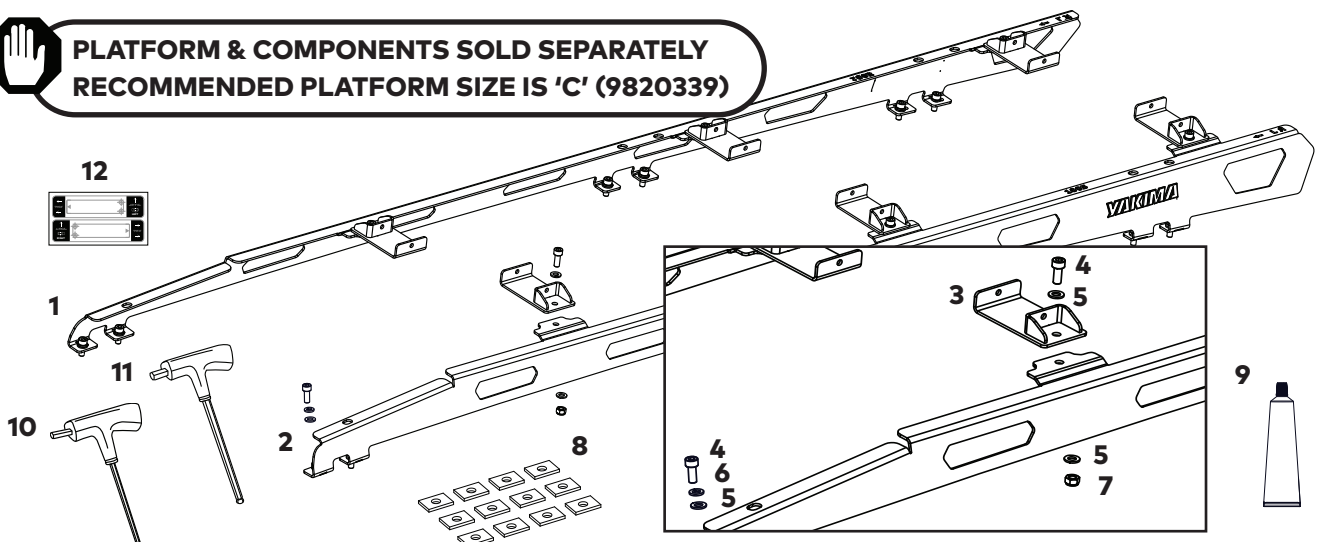

## REMOVING FIXED POINT COVERS - BARE ROOF ONLY

1

### REMOVE FIXED POINT COVERS.

Using an appropriate trim removal tool, carefully remove all six fixed point covers in vehicle roof.

Using a phillips head screw driver, remove the two plastics screws in each fixed point.

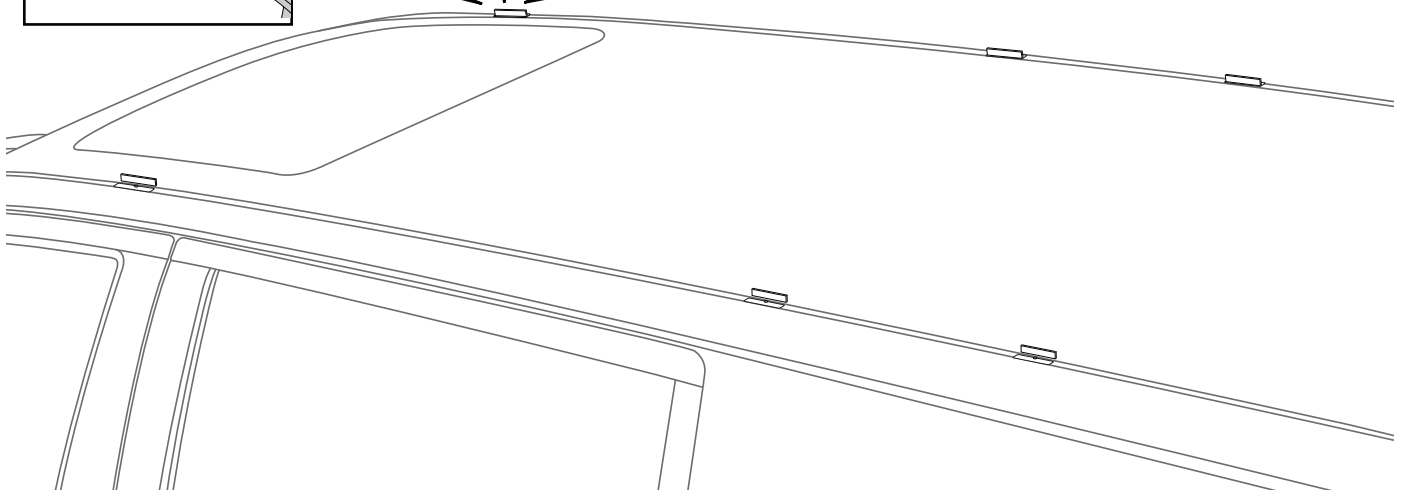
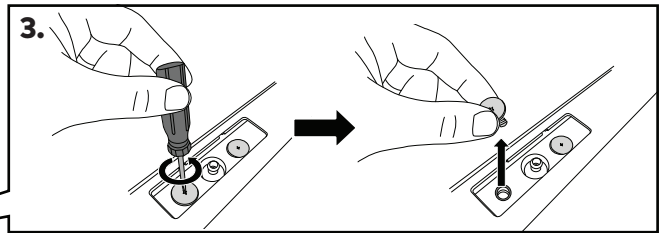
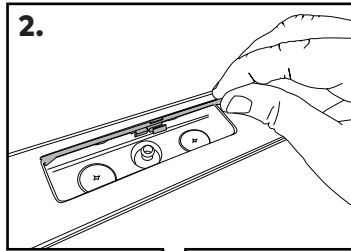
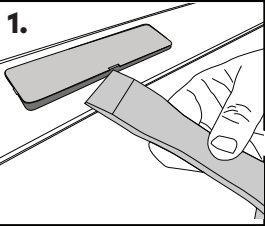
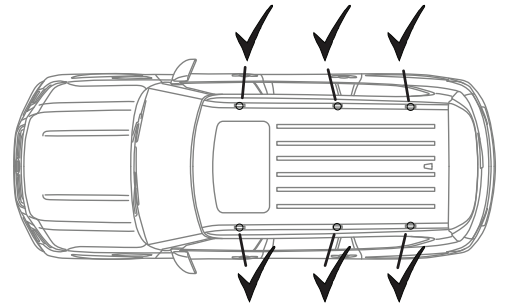

## RAIL REMOVAL - RAISED RAIL ONLY

1

### REMOVE PLASTIC RAIL END COVERS.

Using an appropriate trim removal tool, release the plastic rail end covers by carefully levering the trim removal tool downwards and squeezing the covers until the outer clips release.

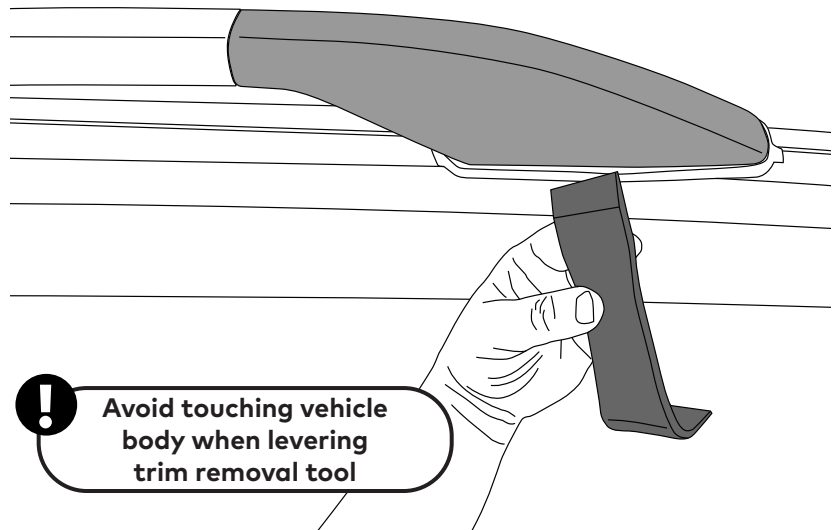

**!** Avoid touching vehicle body when levering trim removal tool

**2****REMOVE PLASTIC CENTER RAIL FASTENER COVERS.**

Using an appropriate trim removal tool, remove the plastic center rail fastener cover.

Repeat on opposite side of vehicle.

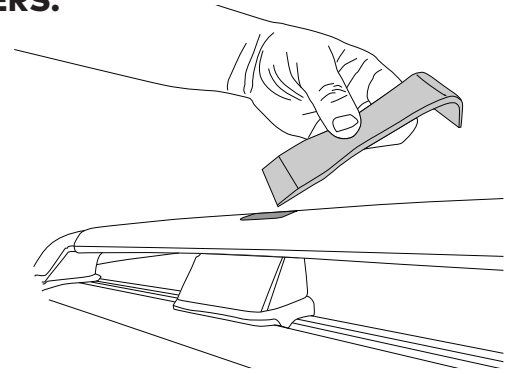
**3****REMOVE FRONT AND REAR RAIL FASTENERS.**

Remove exposed front and rear rail fasteners using a 13 mm socket wrench or breaker bar. Repeat on opposite side of vehicle.

Store removed fasteners away in a safe place.

**NOTE** - A rattle gun may be required if the factory Loctite is too difficult to break loose.

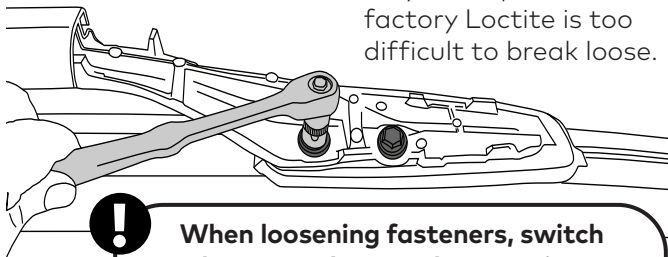

**When loosening fasteners, switch between them to drop tension progressively. If not, the nutplate inside the roof cavity may come loose.**

**4****REMOVE CENTER RAIL FASTENERS.**

Remove exposed center rail fastener using a T30 torx key.

Repeat on opposite side of vehicle.

Store removed fasteners away in a safe place.

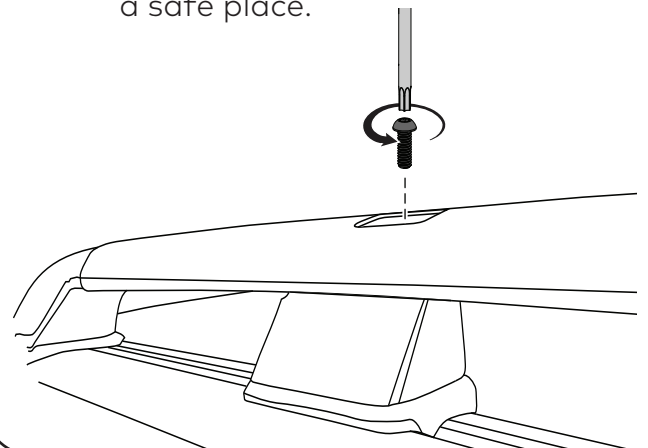
**5****REMOVE RAILS.**

Lift roof rails upwards and carefully remove from the roof.

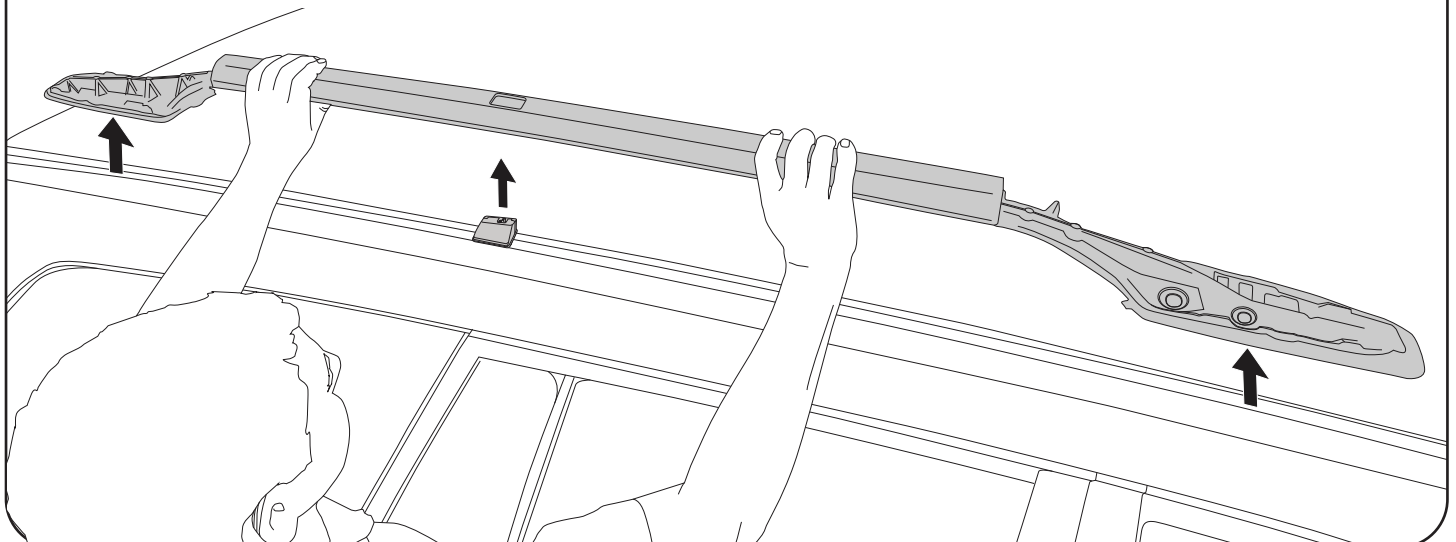

## 6 REMOVE CENTER RAIL COVER.

Remove the center rail cover by inserting a flat head screw driver into the rail cover gaps and lever off.

Repeat on opposite side of vehicle.

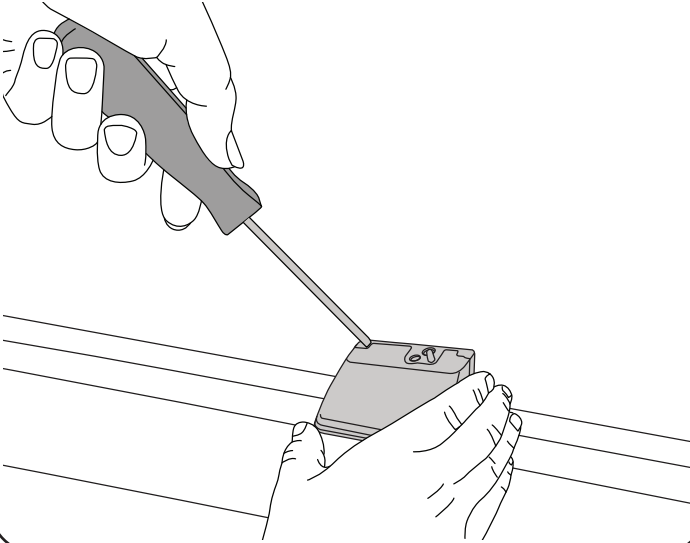

## 7 REMOVE CENTER RAIL MOUNTING HARDWARE.

Using a 13 mm socket wrench, remove the bolt from the center rail mounting point.

Remove the center rail mounting point from the roof. Repeat on opposite side of vehicle.

Store removed hardware away in a safe place.

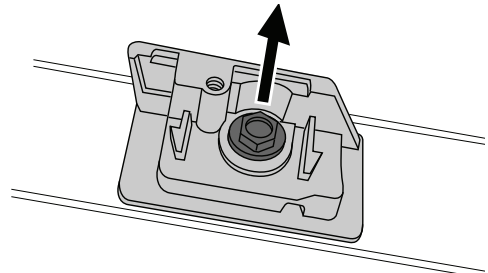

## IDENTIFYING YOUR VEHICLE



### IDENTIFYING PRE-FACELIFT AND POST-FACELIFT VEHICLES.

Before proceeding it is important to identify whether the vehicle being prepared is pre-facelift or post-facelift.

To assist in identification, the main design feature differences between pre-facelift and post-facelift vehicles are illustrated below.

For **pre-facelift** vehicles proceed directly to Mounting RuggedLine on page 7.

For **post-facelift** vehicles continue to Preparation of Middle Fixed Point on page 5.



**PRE-FACELIFT**  
Proceed directly to Mounting RuggedLine on page 7.

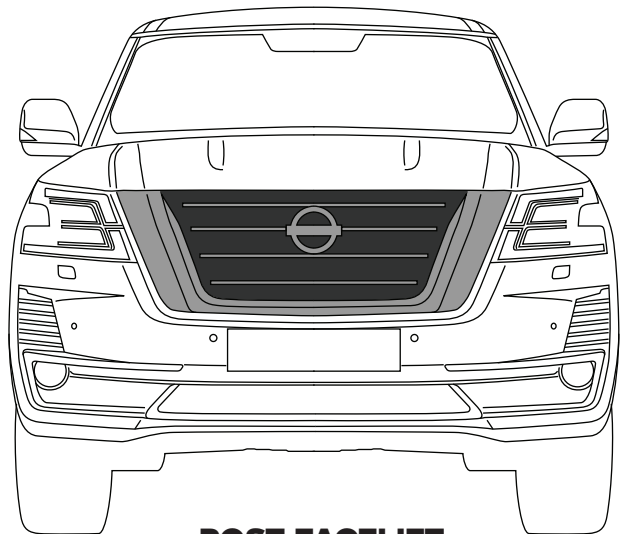

**POST-FACELIFT**  
Continue to Preparation of Middle Fixed Points on page 5.

## PREPARATION OF MIDDLE FIXED POINTS

1

### FAMILIARISE YOURSELF WITH THE TEMPLATE STICKER INSTRUCTIONS.

Read the printed instructions on each template sticker before attempting to apply.



It is essential to ensure the template sticker is positioned correctly. Correct positioning is achieved by lining up the **bold printed line** portion of the opening outline on the template sticker with the front edge of the existing middle fixed point opening in the vehicle roof. Ensure you have correctly identified the bold portion of the printed outline before attempting to apply the template sticker.

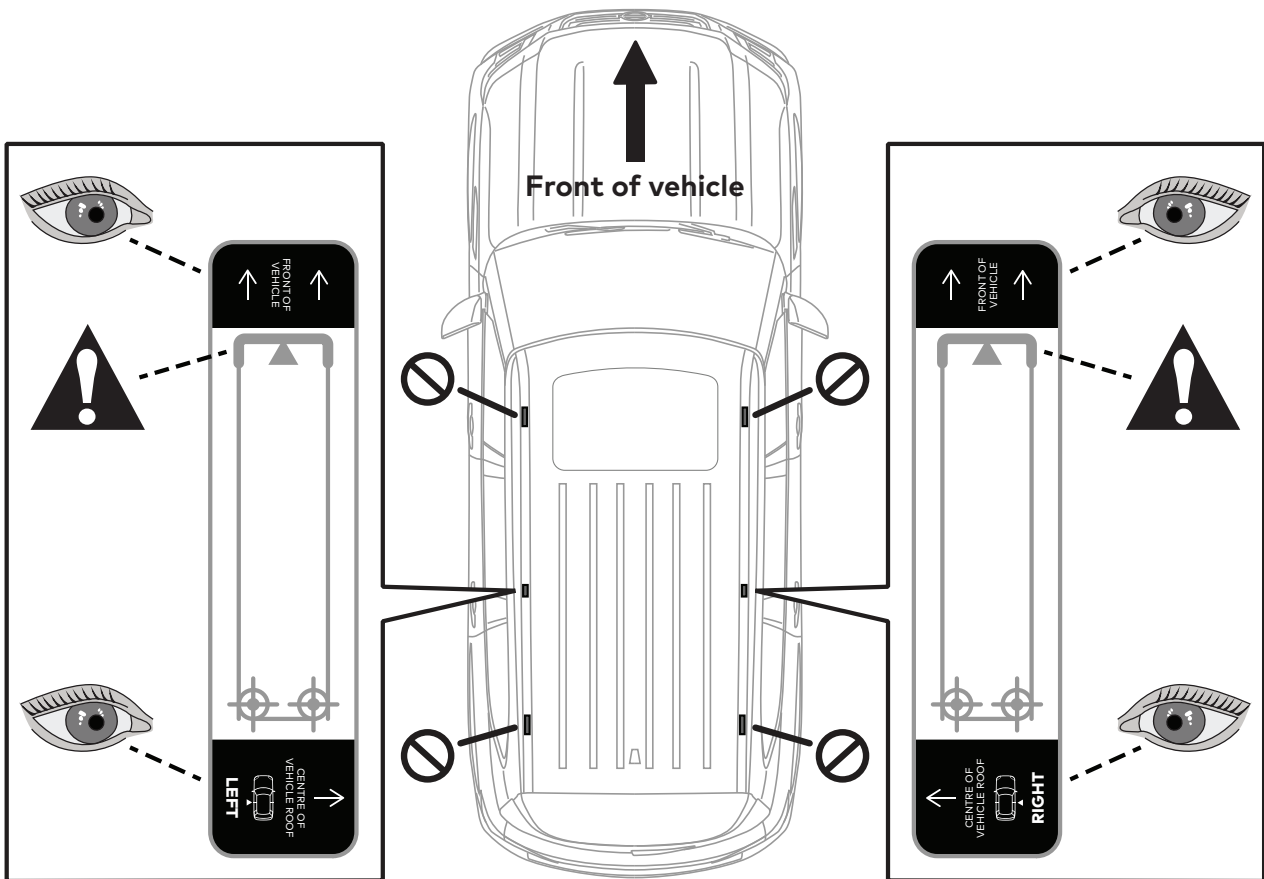

2

### APPLYING MIDDLE FIXED POINT TEMPLATE STICKERS.

Apply the appropriate side template sticker to the appropriate side middle fixed point ensuring it is positioned correctly by lining up the **bold printed line** portion on the template sticker with the front edge of the existing middle fixed point opening.



Once positioned correctly the template sticker should sit perpendicular to the vehicle roof edge as shown.

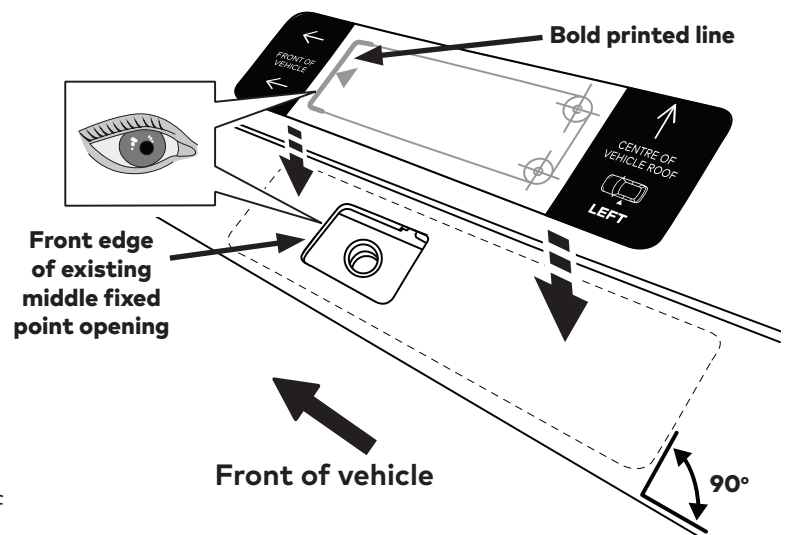

**NOTE** - Left hand side template sticker shown.

**3****DRILL TEMPLATE STICKER HOLES.**

Once correct positioning of the template sticker has been confirmed, drill the marked drill holes. It is recommended to use a 5 mm drill stop.

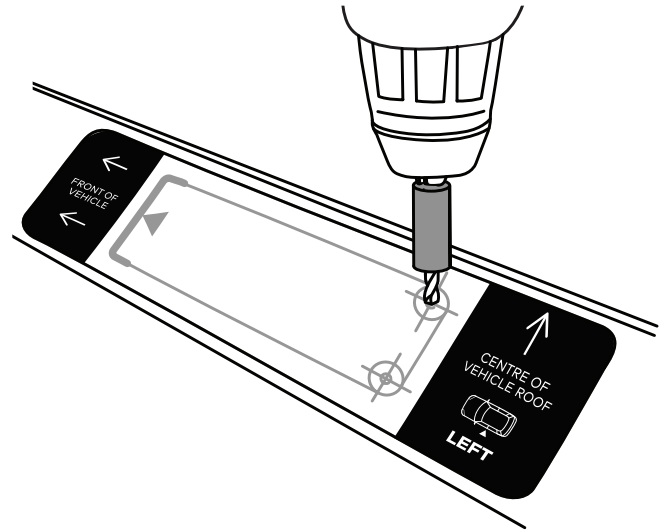
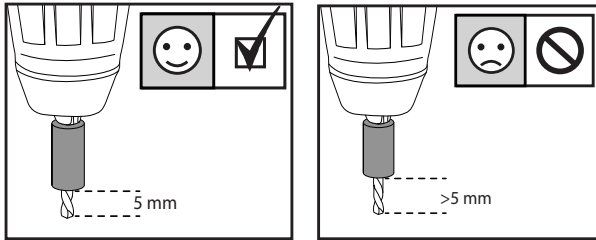

**NOTE** - Left hand side template sticker shown.

**4****CUT FIXED POINT HOLE.**

Using a Dremel, carefully cut along the printed cut lines on the template sticker between the two drilled holes and the existing middle fixed point opening to create a longer middle fixed point opening.

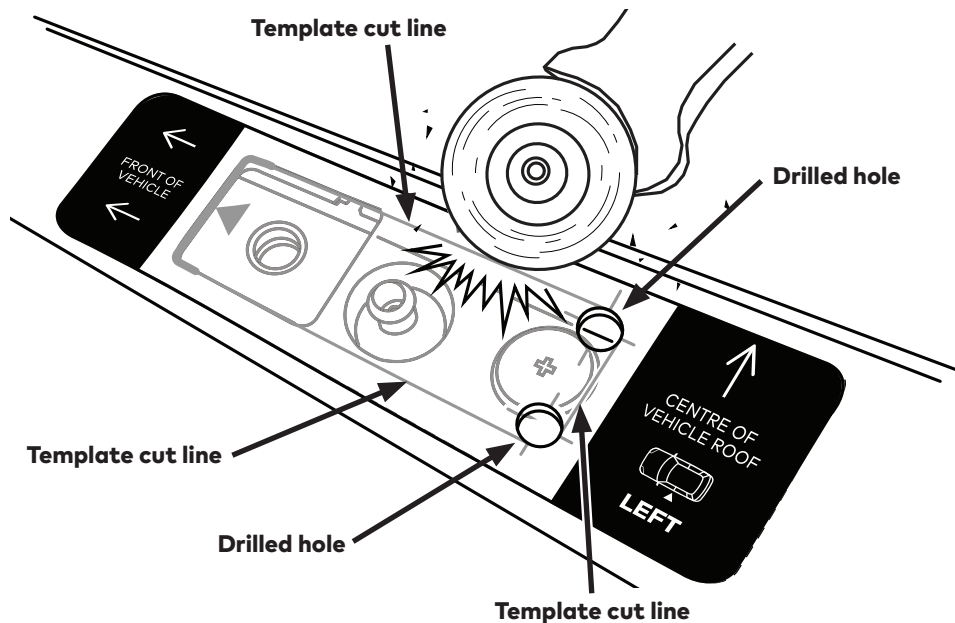
**5****REMOVE CUTTING DEBRIS.**

Remove any template sticker remnants and vacuum away any remaining cutting debris.

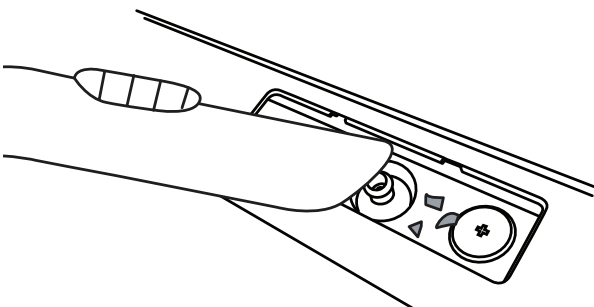
**6****REMOVE PLUG.**

Using a philips head screwdriver, remove the existing plug from the second hole.

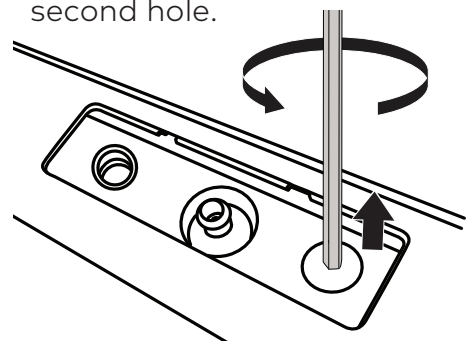



## MOUNTING RUGGEDLINE

### 1 CLEAN ROOF.

Wipe clean any dirt that may have built up in and around all mounting holes.

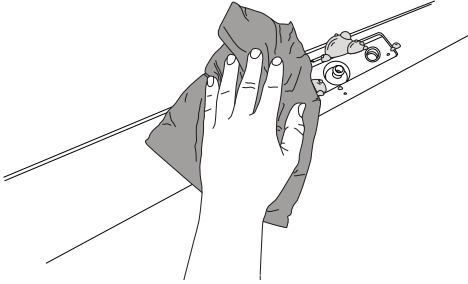

### 2 SEAL NON-THREADED HOLES.

Seal all non-threaded holes using a liberal application of the supplied silicone sealant.

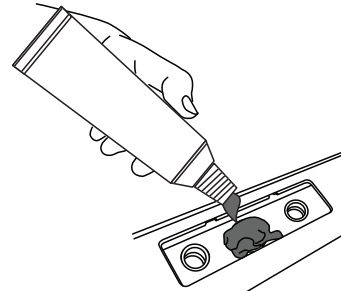

### 3 AFFIX FOAM ADHESIVE.

Apply foam adhesive over all 12 mounting holes in the vehicle's fixed points, with adhesive side to vehicle.

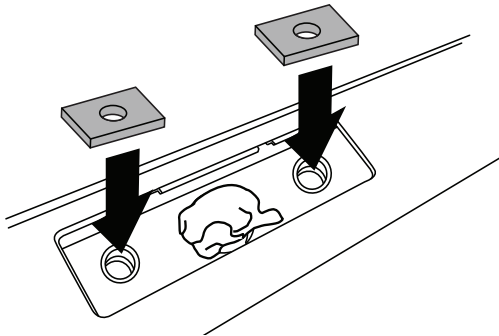

### 4 APPLY SILICONE SEALANT.

Liberally apply the supplied silicone sealant to the inside surface and on top of each hole **on one side of vehicle.**

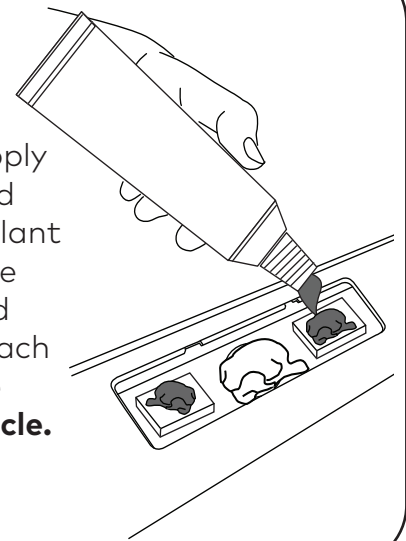

### 5 POSITION RUGGEDLINE ON VEHICLE ROOF.

Referring to the left-right orientation on top of each RuggedLine, carefully place one side of the RuggedLine onto vehicle roof as shown. Line up the mounting holes on the bottom tabs to those exposed on the roof. The tabs are to face in towards the vehicle.

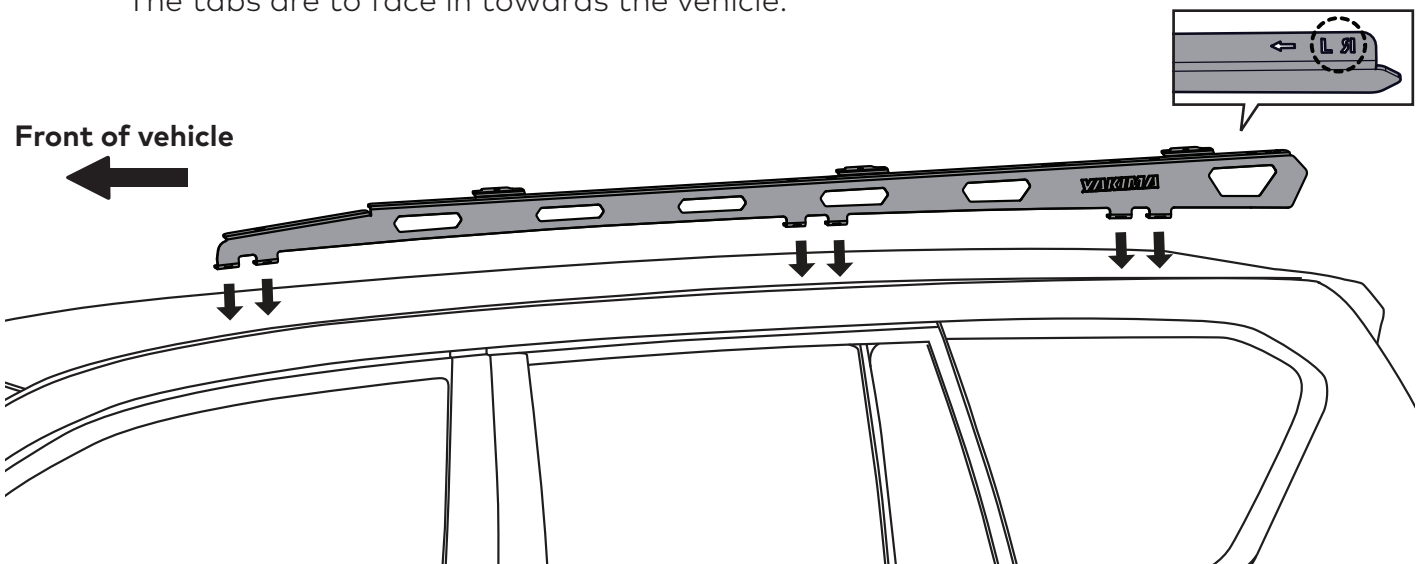

## 6 ASSEMBLE RUGGEDLINE HARDWARE.

Assemble the M8 x 20 mm socket head cap screw, M8 spring washer and washer as shown and place into mounting holes on bottom tabs of RuggedLine. Ensure hardware and holes align with the holes on roof.

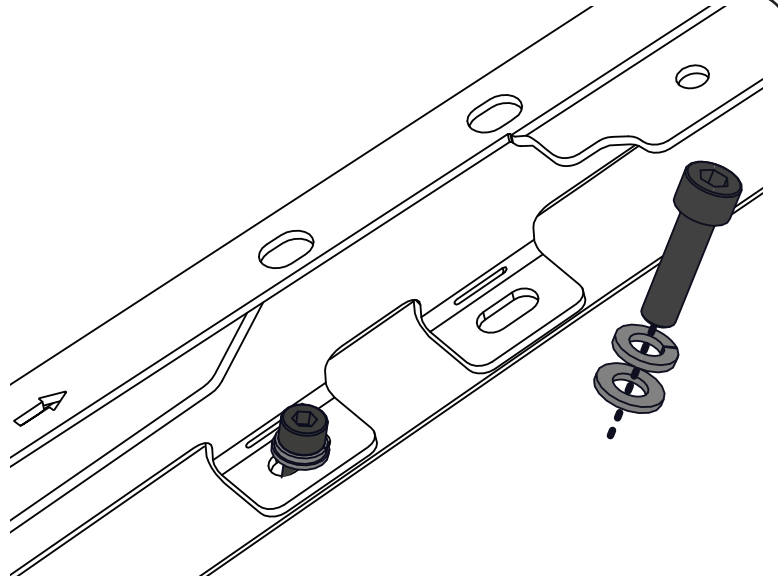

## 7 TIGHTEN RUGGEDLINE HARDWARE.

Using the 6 mm T-handle ball end allen key, and avoiding damage to the powder coat, start to carefully secure the RuggedLine by tightening the M8 socket head cap screws to 7 Nm into the mounting holes in roof.

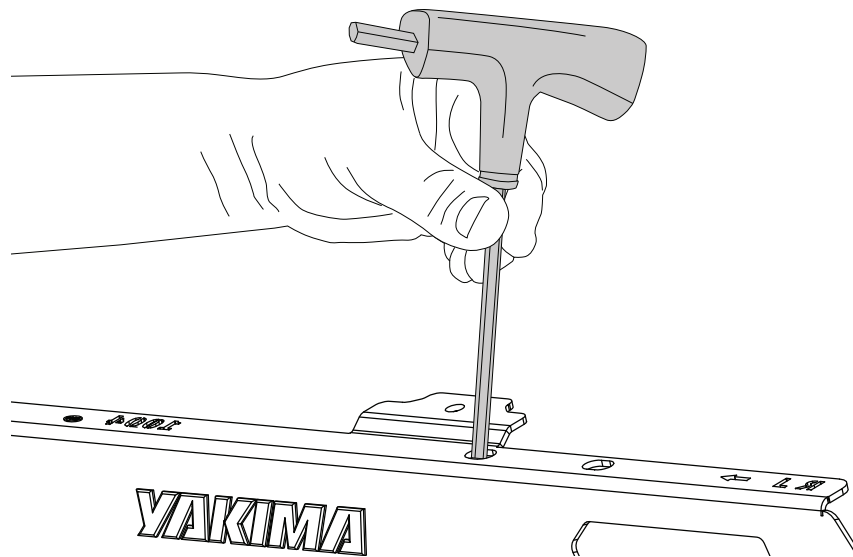

## 8 REPEAT STEPS TO OPPOSITE SIDE.

Repeat steps 4-7 on pages 7-8 for securing opposite side of RuggedLine.

Ensure both RuggedLine are securely positioned on vehicle roof. Check each screw is secure before proceeding to install LockNLoad platform to your RuggedLine.

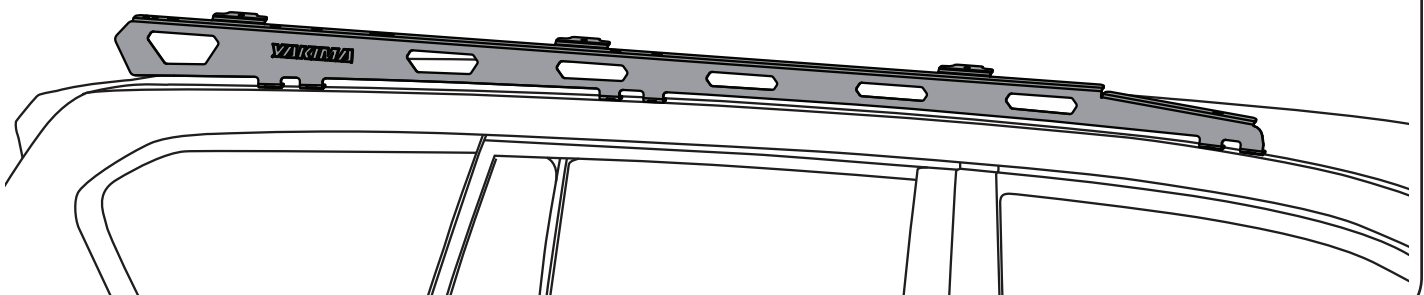



# 9

## PIVOT BRACKET ASSEMBLIES.

Retain the 6 mm T-handle ball end allen key and not yet installed pivot brackets, M8 x 20 mm socket head cap screws, M8 nyloc nuts and M8 washers.



These components will be required for mounting your LockNLoad platform to your newly installed RuggedLine.

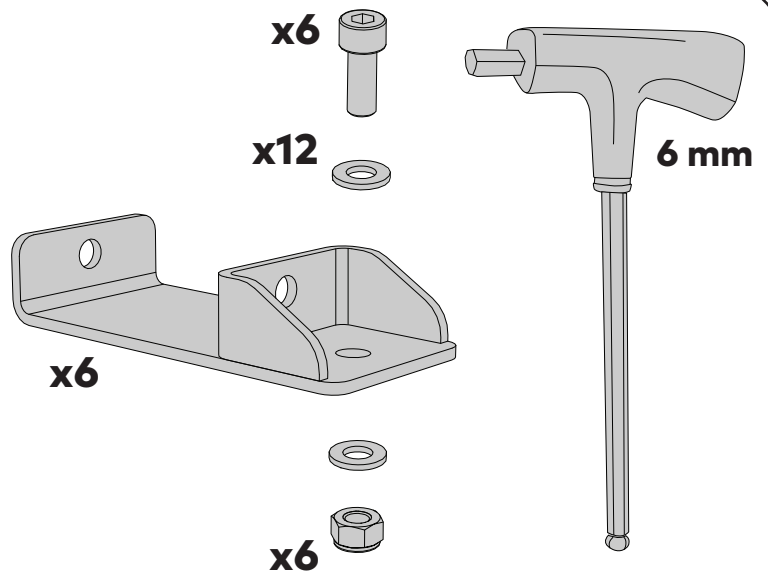

# !

**NOW SWITCH TO YOUR LOCKNLOAD PLATFORM INSTRUCTIONS AND CONTINUE FROM THE 'RUGGEDLINE MOUNTING INSTRUCTIONS' PAGE.**

**NOTE: THE WIND DEFLECTOR CANNOT BE INSTALLED DUE TO THE SUNROOF.**

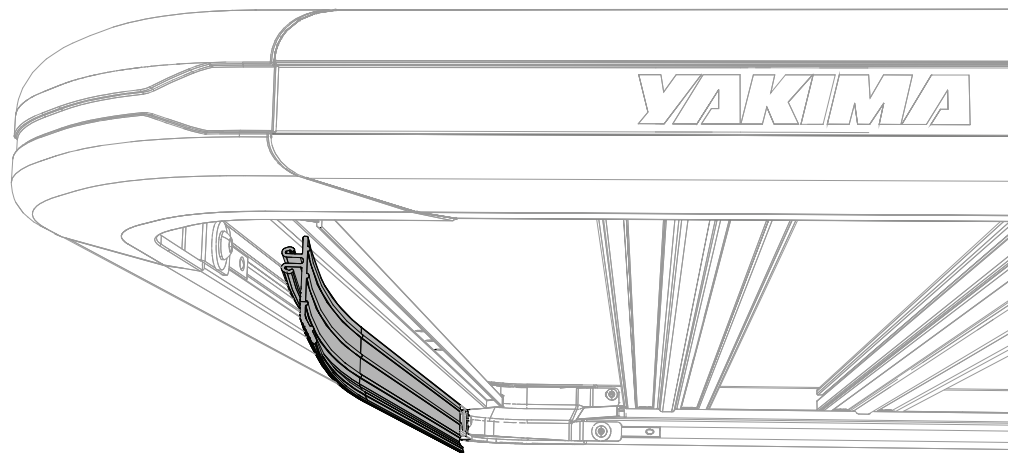



[www.yakima.com.au](http://www.yakima.com.au)  
[www.yakima.co.nz](http://www.yakima.co.nz)  
[www.yakima.com](http://www.yakima.com)  
[www.yakima.eu](http://www.yakima.eu)

**YAKIMA AUSTRALIA PTY LTD**

17 Hinkler Court  
Brendale, QLD 4500  
Australia  
1800 143 548

**YAKIMA PRODUCTS, INC.**

4101 Kruse Way  
Lake Oswego, OR  
97035-2541  
USA  
888 925 4621  
[yakima.com/support](http://yakima.com/support)