

K719

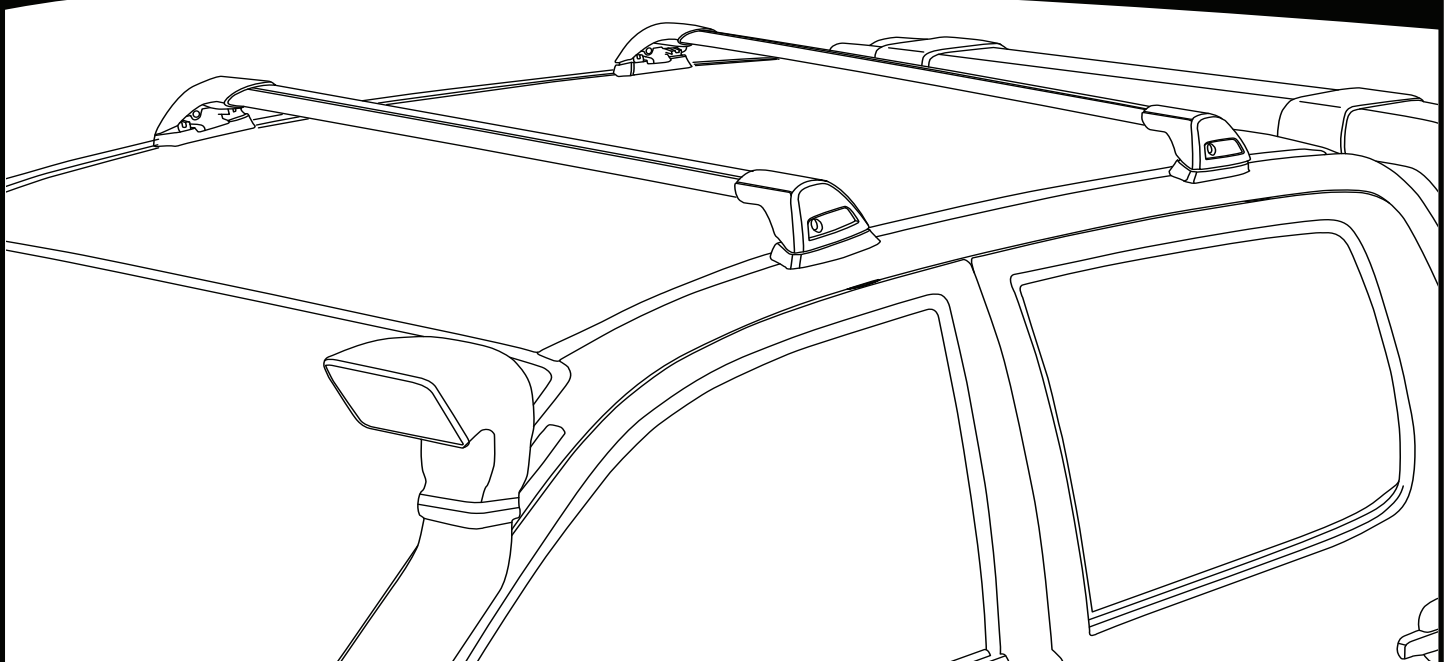

Instructions

CAUTION: Professional installation recommended • **ACHTUNG:** Installation nur durch qualifizierten Fachmann • **PRECAUCIÓN:** Sólo instalación profesional • **ATTENTION :** Installation professionnelle obligatoire • **ADVARSEL:** Kun profesjonell montering • **CUIDADO:** Instalação feita apenas por profissionais • **ВНИМАНИЕ!** Необходима профессиональная инсталляция • **ATTENZIONE:** Solo per installazione professionale • **UWAGA:** Montaż musi być przeprowadzony przez specjalistę • **UPOZORNĚNÍ:** Je nutná odborná montáž • **UPOZORNENIE:** Potrebná odborná montáž • **WAARSCHUWING:** Montage uitsluitend door een vakman • **VARNING:** Installeras av fackman • **OPMÆRKSOMHED:** Professionel installation anbefales • **УВАГА:** рекомендується професійна установка • **HUOMIO:** Ammattimaista asennusta suositellaan



EN NOT SUITABLE FOR ROOF TOP TENT USE.
DE NICHT FÜR DEN DACHZELTGEBRAUCH GEEIGNET.
ES NO SE RECOMIENDA SU USO EN TIENDAS DE CAMPAÑA DE TECHO PARA VEHÍCULOS.
FR NON ADAPTÉ POUR L'UTILISATION EN TENTE DE TOIT.
NO IKKE EGNET FOR TAKTELTBruk.
PT NÃO ADEQUADO PARA UTILIZAÇÃO DE TENDA DE TEJADILHO.
RU НЕ ПОДХОДИТ ДЛЯ ИСПОЛЬЗОВАНИЯ АВТОМОБИЛЬНОЙ ТЕНТ-ПАЛАТКИ НА КРЫШУ.

IT NON ADATTO ALL'USO DI TENDE DA TETTO.
PL NIEODPOWIEDNI DO UŻYTKU Z NAMIOTEM DACHOWYM.
CS NENÍ VHODNÝ PRO POUŽITÍ VE STŘEŠNÍCH STANECH.
SK NIE JE VHODNÉ NA POUŽITIE AKO PLACHTOVINA NA ZAKRYTIE STRECHY.
NL NIET GESCHIKT VOOR GEBRUIK MET EEN DAKTENT.
SV EJ LÄMPLIG FÖR ANVÄNDNING MED TAKTÄLT.
DK IKKE EGNET TIL BRUG MED TAGTEL.
UA НЕ ПІДХОДИТЬ ДЛЯ ВИКОРИСТАННЯ З НАМЕТОМ НА ДАХУ.
FI EI SOVI KATTOTELTTAAN.

MAX kg (lb)

FITTING KIT LOAD RATING IS 75 kg, OR 100 kg WHEN PAIRED WITH HD BARS. 

IMPORTANT:

- LOAD = WEIGHT OF BARS + MOUNTING SYSTEM + ACCESSORIES + CARGO
- PLEASE REFER TO VEHICLE MANUFACTURER SPECIFICATIONS FOR MAX ROOF LOAD CAPACITY OF VEHICLE. THE LOWEST LOAD RATING APPLIES.
- OFFROAD RATING: SCAN QR CODE FOR LOAD RATING GUIDE. REDUCTIONS MAY APPLY.

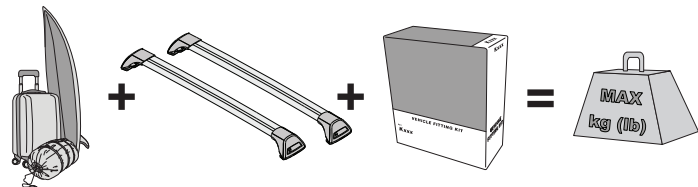

DE**DIE TRAGFÄHIGKEIT DES MONTAGESATZES BETRÄGT 75 KH BZW. 100 KG BEI KOMBINATION MIT HD-STANGEN.** **WICHTIG:**

- LAST = GEWICHT DER STANGEN + MONTAGESYSTEM + ZUBEHÖR + LADUNG
- BITTE BEACHTEN SIE DIE SPEZIFIKATION DES FAHRZEUGHERSTELLERS FÜR DIE MAXIMALE DACHLASTKAPAZITÄT DES FAHRZEUGS. ES GILT DIE NIEDRIGSTE BELASTBARKEIT.
- OFFROAD-BEWERTUNG: SCANNEN SIE DEN QR-CODE, UM EINEN LEITFADEN ZUR BELASTUNGSBEWERTUNG ZU ERHALTEN. MÖGLICHERWEISE BESTEHEN EINSCHRÄNKUNGEN.

**ES****LA CAPACIDAD DE CARGA DEL KIT DE MONTAJE ES DE 75 kg, o 100 kg CUANDO SE UTILIZAN BARRAS HD.** **IMPORTANTE:**

- CARGA = PESO DE LAS BARRAS + SISTEMA DE MONTAJE + ACCESORIOS + CARGA
- CONSULTE LAS ESPECIFICACIONES DEL FABRICANTE DEL VEHÍCULO PARA CONOCER LA CAPACIDAD DE CARGA MÁXIMA DEL TECHO DEL VEHÍCULO. DEBE CONSIDERARSE LA MENOR CAPACIDAD DE CARGA.
- CAPACIDAD EN CARRETERA: ESCANE E EL CÓDIGO QR PARA CONSULTAR LA GUÍA DE CAPACIDAD DE CARGA, YA QUE ES POSIBLE QUE DEBAN APLICARSE REDUCCIONES.

**FR****LA CHARGE NOMINALE DU KIT DE FIXATION EST DE 75 kg OU DE 100 kg LORS DE L'ASSOCIATION AVEC DES BARRES HD.** **IMPORTANT :**

- CHARGE = POIDS DES BARRES + SYSTÈME DE MONTAGE + ACCESSOIRES + CARGAISON
- VEUILLEZ VOUS REPORTER AUX SPÉCIFICATIONS DU CONSTRUCTEUR DU VÉHICULE POUR LA CAPACITÉ DE CHARGE MAXIMALE DU TOIT DU VÉHICULE. LA PLUS FAIBLE CHARGE NOMINALE S'APPLIQUE.
- VALEUR NOMINALE HORS ROUTE : SCANNEZ LE QR CODE POUR LE GUIDE DES CHARGES NOMINALES. DES RÉDUCTIONS PEUVENT S'APPLIQUER.

**NO****KOBLINGSSETTLASTEANGIVELSE ER 75 kg, ELLER 100 kg, NÅR PARET MED HD-STENGER.** **VIKTIG:**

- LAST = VEKT PÅ STENGER + MONTERINGSSYSTEM + TILBEHØR + LAST
- SE KJØRETØYILVIRKERENS SPESIFIKASJONER FOR MAKS. TAKLASTKAPASITET FOR KJØRETØY. DEN LAVESTE LASTEANGIVELSE GJELDER.
- TERRENGANGIVELSE: SKANN QR-KODE FOR VEILEDNING TIL LASTEANGIVELSE. REDUKSJONER KAN OGSÅ GJELDE.

**PT****A CAPACIDADE DE CARGA DO KIT DE MONTAGEM É DE 75 kg OU DE 100 kg, QUANDO COMBINADO COM HD BARS.** **IMPORTANTE:**

- CARGA = PESO DAS BARRAS + SISTEMA DE MONTAGEM + ACESSÓRIOS + CARGA
- CONSULTE AS ESPECIFICAÇÕES DO FABRICANTE DO VEÍCULO PARA FICAR A PAR DA CAPACIDADE DE CARGA MÁXIMA DO TEJADILHO DO VEÍCULO. APLICA-SE A CAPACIDADE DE CARGA MAIS BAIXA.
- CAPACIDADE TODO-O-TERRENO: LEIA O CÓDIGO QR PARA VISUALIZAR O GUIA DE CAPACIDADE DE CARGA. PODEM APLICAR-SE REDUÇÕES.

**RU****ГРУЗОПОДЪЕМНОСТЬ КОМПЛЕКТА СОСТАВЛЯЕТ 75 КГ (ИЛИ 100 КГ ПРИ КОМПЛЕКТАЦИИ С УСИЛЕННЫМИ ШТАНГАМИ).** **ВАЖНАЯ ИНФОРМАЦИЯ:**

- НАГРУЗКА = ВЕС ШТАНГ + СИСТЕМА КРЕПЛЕНИЯ + ПРИНАДЛЕЖНОСТИ + ГРУЗ
- МАКСИМАЛЬНАЯ ГРУЗОПОДЪЕМНОСТЬ КРЫШИ АВТОМОБИЛЯ УКАЗАНА В СПЕЦИФИКАЦИЯХ ПРОИЗВОДИТЕЛЯ АВТОМОБИЛЯ. ПРИМЕНЯЕТСЯ НАИМЕНЬШИЙ ПОКАЗАТЕЛЬ НАГРУЗКИ.
- КЛАСС ПРОХОДИМОСТИ ПО БЕЗДОРОЖЬЮ: ДЛЯ ПОЛУЧЕНИЯ ИНФОРМАЦИИ ПО НОМИНАЛЬНОЙ ГРУЗОПОДЪЕМНОСТИ ОТСКАНИРУЙТЕ QR-КОД. МОГУТ ПРИМЕНЯТЬСЯ УМЕНЬШЕННЫЕ ПОКАЗАТЕЛИ

**IT****LA PORTATA DEL KIT DI MONTAGGIO E' DI 75 kg, O DI 100 kg SE DOTATO DI BARRE HD.** **IMPORTANTE:**

- CARICO = PESO DELLE BARRE + SISTEMA DI MONTAGGIO + ACCESSORI + CARICO
- FARE RIFERIMENTO ALLE SPECIFICHE DEL COSTRUTTORE DEL VEICOLO PER LA CAPACITÀ MASSIMA DI CARICO SUL TETTO DEL VEICOLO. SI APPLICA IL COEFFICIENTE DI CARICO PIÙ BASSO.
- VALUTAZIONE OFFROAD: SCANSIONARE IL CODICE QR PER IL CARICO NOMINALE. POSSONO ESSERE APPLICATE RIDUZIONI".

**PL****OBciążENIE ZNAMIONOWE ZESTAWU MONTAżOWEGO WYNOSI 75 kg LUB 100 kg, JEŚLI UŻYTE ZOSTANA PRĘTY HD.** **IMPORTANTE:**

- CARICO = PESO DELLE BARRE + SISTEMA DI MONTAGGIO + ACCESSORI + CARICO
- FARE RIFERIMENTO ALLE SPECIFICHE DEL COSTRUTTORE DEL VEICOLO PER LA CAPACITÀ MASSIMA DI CARICO SUL TETTO DEL VEICOLO. SI APPLICA IL COEFFICIENTE DI CARICO PIÙ BASSO.
- VALUTAZIONE OFFROAD: SCANSIONARE IL CODICE QR PER IL CARICO NOMINALE. POSSONO ESSERE APPLICATE RIDUZIONI".

**CS****NOSNOST MONTÁŽNÍ SADY JE 75 KG NEBO 100 KG, POKUD JE VYBAVENA TYČEMI HD.** **DŮLEŽITÉ:**

- ZATÍŽENÍ = HMOTNOST TYČÍ + MONTÁŽNÍ SYSTÉM + PŘÍSLUŠENSTVÍ + NÁKLAD
- MAXIMÁLNÍ NOSNOST STŘECHY VOZIDLA ZJISTĚTE U VÝROBCE VOZIDLA. PLATÍ NEJNIŽŠÍ NOSNOST.
- HODNOCENÍ PRO JÍZDU V TERÉNU: NASKENUJTE QR KÓD PRO ZÍSKÁNÍ PRŮVODCE NOSNOSTÍ. MOHOU SE UPLATNIT SNIŽENÍ.

**SK****NOSNOSŤ MONTÁŽNEJ SÚPRAVY JE 75 kg, ALEBO 100 kg V KOMBINÁCI S HD TYČAM.** **DŮLEŽITÉ:**

- ZAŤAŽENIE = HMOTNOSŤ TYČÍ + MONTÁŽNY SYSTÉM + PŘÍSLUŠENSTVO + NÁKLAD
- MAXIMÁLNE ZAŤAŽENIE STRECHY VOZIDLA NÁJDETE V TECHNICKÝCH PARAMETROCH OD VÝROBCU VOZIDLA. PLATÍ NAJNIŽŠIE MENOVIÉ ZAŤAŽENIE.
- MENOVIÉ HODNOTY DO TERÉNU: INFORMÁCIE O MENOVIÝCH HODNOTÁCH ZAŤAŽENIA ZÍSKATE NASKENOVANÍM QR KÓDU. MÔŽU PLATIŤ REDUKCIE.

**NL****LAADVERMOGEN VAN DE MONTAGESET IS 75 kg, OF 100 kg IN COMBINATIE MET HD-STANGEN.** **BELANGRIJK:**

- LADING = GEWICHT VAN DE STANGEN + OPHANGSISTEEM + ACCESSOIRES + VRACHT
- RAADPLEEG DE SPECIFICATIES VAN DE VOERTUIGFABRIKANT VOOR DE MAXIMALE LAADCAPACITEIT VAN HET VOERTUIG. HET LAAGSTE LAADVERMOGEN IS VAN TOEPASSING.
- OFFROAD-VERMOGEN: SCAN DE QR-CODE VOOR INSTRUCTIES OVER LAADVERMOGEN. MOGELIJK IS DIT LAGER.



SV**MONTERINGSSATSENS LASTKLASSIFICERING ÄR 75 kg, ELLER 100 kg NÄR DEN ANVÄNDS MED HD-STÄNGER.** **VIKTIGT:**

- LAST = VIKT PÅ STÄNGER + MONTERINGSSYSTEM + TILLBEHÖR + LAST
- SE FORDONSTILLVERKARENS SPECIFIKATIONER FÖR FORDONETS MAXIMALA TAKLASTKAPACITET. GÄLLER DEN LÄGSTA LASTKLASSIFICERINGEN.
- TERRÄNGKLASSIFICERING: SKANNA QR-KODEN FÖR LASTKLASSIFICERINGSGUIDEN. REDUKTIONER I LASTKLASSIFICERING KAN GÄLLA.

**DK****MONTERINGSPAKKENS BELASTNINGSEVNE ER 75 KG, ELLER 100 KG SAMMEN MED HD-STÆNGER.** **VIGTIGT:**

- BELASTNING = STÆNGERNES VÆGT + MONTERINGSSYSTEM + TILBEHØR + LAST
- SE KØRETØJSFABRIKANTENS SPECIFIKATIONER FOR KØRETØJETS MAKSIMALE BELASTNINGSKAPACITET FOR TAGLAST. DEN LAVESTE BELASTNINGSEVNE GÆLDER.
- OFFROAD-KLASSIFICERING SCAN QR-KODEN FOR GUIDE TIL BELASTNINGSEVNE. DER KAN VÆRE BEGRÆNSNINGER





**UA****НОМИНАЛЬНЕ НАВАНТАЖЕННЯ МОНТАЖНОГО КОМПЛЕКТУ 75 кг АБО 100 кг РАЗОМ ІЗ ПЛАНКАМИ HD.** **ВАЖЛИВО:**

- НАВАНТАЖЕННЯ = ВАГА ПЛАНОК + МОНТАЖНА СИСТЕМА + ПРИЛАДДА + ВАНТАЖ
- ДИВ. ТЕХНІЧНІ ХАРАКТЕРИСТИКИ ВИРОБНИКА АВТОМОБІЛЯ ЩОДО МАКСИМАЛЬНОЇ ВАНТАЖОПІДЙОМНОСТІ ДАХУ АВТОМОБІЛЯ. ЗАСТОСОВУЄТЬСЯ НАЙНИЖЧЕ ЗНАЧЕННЯ НОМИНАЛЬНОГО НАВАНТАЖЕННЯ.
- ПРИПУСТИМЕ НАВАНТАЖЕННЯ В УМОВАХ БЕЗДОРІЖЖА: ВІДСКАНУЙТЕ QR-КОД ДЛЯ ОТРИМАННЯ ВКАЗИВОК ЩОДО НАВАНТАЖЕННЯ. МОЖУТЬ ЗАСТОСОВУВАТИСЯ ЗНИЖЕННЯ ЗНАЧЕНЬ НОМИНАЛЬНИХ ПАРАМЕТРІВ.

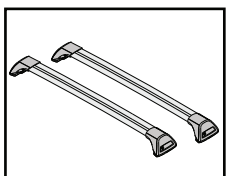
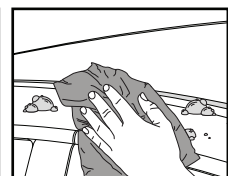
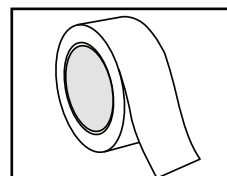
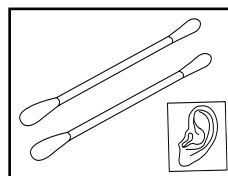
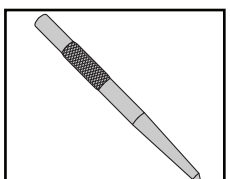
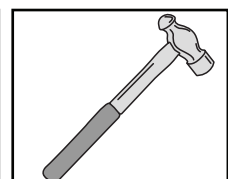
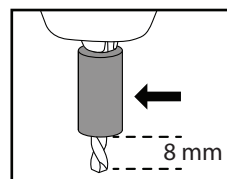
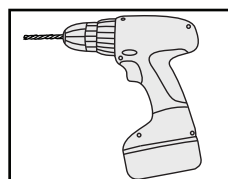
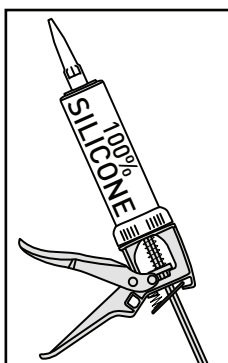
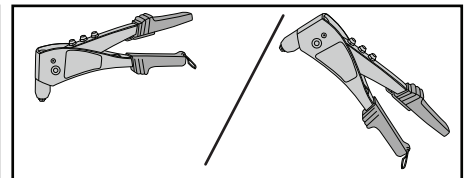
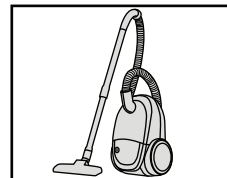
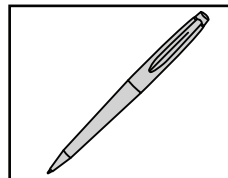
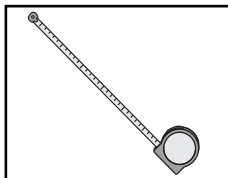
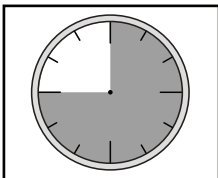
**FI****SOVITUSSARJAN ENIMMÄISKUORMITUS ON 75 KG TAI 100 KG, KUN KÄYTETÄÄN HD-TANKOJA.** **TÄRKEÄÄ:**

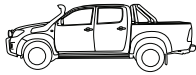
- KUORMA = TANKOJEN PAINO + ASENNUSJÄRJESTELMÄ + LISÄVARUSTEET + LASTI
- TARKISTA AJONEUVON VALMISTAJAN TEKNISET TIEDOT AJONEUVON KATON ENIMMÄISKUORMASTA. PIENEN ENIMMÄISKUORMITUS PÄTEE.
- ENIMMÄISKUORMITUS MAASTOSSA: QR-KOODI ON SKANNATTAVA ENIMMÄISKUORMITUSOHJEEN SAAMISEKSI. OLEMASSA VOI OLLA PÄTEVIÄ VÄHENNYksiÄ.

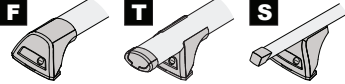
**EN** ALWAYS REFER TO OUR WEBSITE FOR THE LATEST VERSION OF INSTRUCTIONS.**DE** BESUCHEN SIE IMMER UNSERE WEBSITES, UM DIE NEUESTE VERSION DER ANWEISUNGEN ZU ERHALTEN.**ES** CONSULTE NUESTRAS PÁGINAS WEB PARA VER LA ÚLTIMA VERSIÓN DE LAS INSTRUCCIONES.**FR** RÉFÉREZ VOUS TOUJOURS À NOS SITES INTERNET POUR CONSULTER LA DERNIÈRE VERSION DES INSTRUCTIONS.**NO** DEN NYESTE VERSJONEN AV INSTRUKSJONENE ER ALLTID TILGJENGELIG PÅ VÅRE NETTSIDER.**PT** CONSULTE SEMPRE OS NOSSOS WEBSITES PARA OBTER A MAIS RECENTE VERSÃO DAS INSTRUÇÕES.**RU** АКТУАЛЬНАЯ ВЕРСИЯ ИНСТРУКЦИИ ДОСТУПНА НА НАШЕМ САЙТЕ.**IT** FARE SEMPRE RIFERIMENTO AI NOSTRI SITI WEB PER L'ULTIMA VERSIONE DELLE ISTRUZIONI.**PL** ZAWSZE SPRAWDZAJ NASZĄ STRONĘ INTERNETOWĄ, ABY UZYSKAĆ NAJNOWSZĄ WERSJĘ INSTRUKCJI.**CS** NEJNOVĚJŠÍ VERZI POKYNŮ VŽDY NAJDETE NA NAŠÍ WEBOVÉ STRÁNCE.**SK** POSLEDNÚ VERZIU POKYNOV VŽDY NAJDETE NA NAŠICH WEBOVÝCH STRÁNKACH.**NL** RAADPLEEG ALTIJD ONZE WEBSITES VOOR DE MEEST RECENTE VERSIE VAN DE INSTRUCTIES.**SV** SE ALLTID VÅRA WEBBPLATSER FÖR DEN SENASTE VERSIONEN AV INSTRUKTIONERNA.**DK** DEN NYESTE VERSION AF VEJLEDNINGERNE ER ALTID TILGÆNGELIG PÅ VORES HJEMMESIDER.**UA** ОСТАННЯ ВЕРСІЯ ІНСТРУКЦІЇ ЗАВЖДИ ДОСТУПНА НА НАШОМУ САЙТІ.**FI** KATSO AINA VERKKOSIVUSTOILTAMME UUSIN VERSIO OHJEISTA.**REQUIRED • ERFORDERLICH • REQUERIDOS • OBLIGATOIRE • NØDVENDIG • NECESSÁRIO • OBBLIGATORIO
POTRZEBY • NEVYHNUTELNÉ • NEVYHNUTNÉ • NODIG • NÖDVÄNDIG • PÅKRÆVET • ПОТРІБНА • EDELLYTETÄÄN**

			
Chevrolet Colorado Crew Cab, 4dr Ute 12-20	EU	75 kg (165 lb)	100 kg (220 lb)
Chevrolet Colorado Extended Cab, 4dr Ute 12+	EU	75 kg (165 lb)	100 kg (220 lb)
Chevrolet Colorado Single Cab, 2dr Ute 13-20	EU	35 kg (77 lb)	50 kg (110 lb)
Dodge Ram 1500 Crew Cab DS, 4dr Ute 09-12	AU, NZ	75 kg (165 lb)	100 kg (220 lb)
Dodge Ram 1500 Crew Cab, 4dr Ute 09-12	EU	75 kg (165 lb)	100 kg (220 lb)
Dodge Ram 1500, Quad Cab 4dr Ute 09-12	AU, EU, NZ	75 kg (165 lb)	100 kg (220 lb)
Holden Colorado Single Cab, 2dr Ute 12-20	AU, NZ	35 kg (77 lb)	50 kg (110 lb)
Holden Colorado Space Cab, 4dr Ute 12-20	AU, NZ	75 kg (165 lb)	100 kg (220 lb)
Hyundai Ioniq 6, 4dr Sedan 23+	AU, EU, NZ	75 kg (165 lb)	75 kg (165 lb)
Isuzu D-Max SX Crew Cab, 4dr Ute 12-Aug 20	AU, NZ	75 kg (165 lb)	100 kg (220 lb)
Isuzu D-Max Extended Cab, 4dr Ute 12-20	EU	75 kg (165 lb)	100 kg (220 lb)
Isuzu D-Max Single Cab, 2dr Ute 12-19	EU	35 kg (77 lb)	50 kg (110 lb)
Isuzu D-Max SX/EX Single Cab, 2dr Ute 12-Aug 20	AU, NZ	35 kg (77 lb)	50 kg (110 lb)
Isuzu D-Max Single Cab, 2dr Ute 20+	EU	35 kg (77 lb)	50 kg (110 lb)
Isuzu D-Max Single Cab, 2dr Ute Sep 20+	AU, NZ	35 kg (77 lb)	50 kg (110 lb)
Isuzu D-Max LS-U/LS-M Space Cab, 4dr Ute 12-Aug 20	AU, NZ	75 kg (165 lb)	100 kg (220 lb)
Isuzu D-Max SX Space Cab, 4dr Ute May 12-Aug 20	AU, NZ	75 kg (165 lb)	100 kg (220 lb)
Isuzu D-Max Space Cab, 4dr Ute 20+	EU	75 kg (165 lb)	100 kg (220 lb)
Isuzu D-Max Space Cab, 4dr Ute Sep 20+	AU, NZ	75 kg (165 lb)	100 kg (220 lb)
Isuzu MU-X LS-M, 5dr SUV 21+	EU	75 kg (165 lb)	75 kg (165 lb)
Isuzu MU-X LS-M, 5dr SUV Aug 21+	AU, NZ	75 kg (165 lb)	75 kg (165 lb)
LDV Deliver 7, 5dr Van 24+	AU, EU, NZ	-	100 kg (220 lb)
LDV e Deliver 7, 5dr Van 24+	AU, EU, NZ	-	100 kg (220 lb)
LDV Deliver 9, 4dr Van Oct 20+	AU, NZ	-	100 kg (220 lb)
LDV Maxus T90 EV, 4dr Ute 22+	EU	75 kg (165 lb)	100 kg (220 lb)
LDV T60/60 Max/eT60 Double Cab, 4dr Ute 17+	AU, NZ	75 kg (165 lb)	100 kg (220 lb)
LDV T60/60 Max/eT60 Single Cab, 4dr Ute Oct 17+	AU, NZ	75 kg (165 lb)	100 kg (220 lb)
Mahindra Genio, 4dr Ute 14+	NZ	75 kg (165 lb)	75 kg (165 lb)
Mahindra Genio, 4dr Ute 16+	AU	75 kg (165 lb)	75 kg (165 lb)
Mazda BT-50 Freestyle Cab, 4dr Ute Oct 20+	AU, NZ	75 kg (165 lb)	100 kg (220 lb)
Mazda BT-50 Single Cab, 2dr Ute Oct 20+	AU, NZ	35 kg (77 lb)	50 kg (110 lb)
Mitsubishi L200 Single Cab, 2dr Ute 15-23	EU	35 kg (77 lb)	35 kg (77 lb)
Mitsubishi Triton Single Cab, 2dr Ute May 15-Jan 24	AU, NZ	35 kg (77 lb)	35 kg (77 lb)
Mitsubishi Triton Single Cab, 2dr Ute 24+	EU	35 kg (77 lb)	35 kg (77 lb)
Mitsubishi Triton Single Cab, 2dr Ute Feb 24+	AU, NZ	35 kg (77 lb)	35 kg (77 lb)
RAM 1500 Crew Cab, 4dr Ute 13-18	EU	75 kg (165 lb)	100 kg (220 lb)
RAM 1500 Crew Cab/Classic Cab, 4dr Ute 13-18	AU, NZ	75 kg (165 lb)	100 kg (220 lb)
RAM 1500 Quad Cab, 4dr Ute 13+	AU, EU, NZ	75 kg (165 lb)	100 kg (220 lb)
RAM 1500, 4dr Ute 19+	AU	75 kg (165 lb)	100 kg (220 lb)
RAM 1500, 4dr Ute 20+	EU, NZ	75 kg (165 lb)	100 kg (220 lb)
RAM 2500 Crew Cab DT, 4dr Ute 20+	AU, EU, NZ	75 kg (165 lb)	100 kg (220 lb)

**CONTENTS • INHALT • CONTENIDO • CONTENU • INNHOLD • CONTEÚDO • СОДЕРЖАНИЕ • CONTENUTO
ZAWARTOŚĆ • OBSAH • OBSAH • INHOUD • INNEHÅLL • INDHOLD • ЗМІСТ • SISÄLLYS**

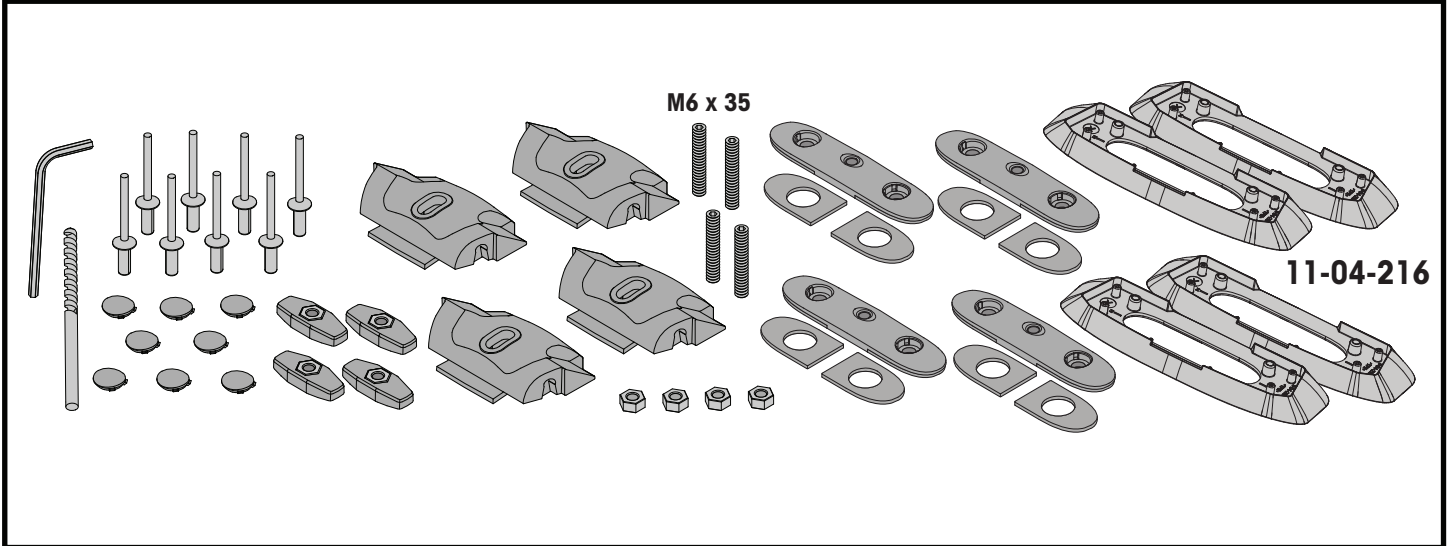

**COMPATIBLE WITH • KOMPATIBEL MIT • COMPATIBLE CON • COMPATIBLE AVEC • KOMPATIBEL MED
• COMPATÍVEL COM • СОВМЕСТИМ С • COMPATIBLE CON • KOMPATYBILNOŚĆ Z • KOMPATIBILNÍ S •
KOMPATIBILNÉ S • COMPATIBEL MET • KOMPATIBEL MED • KOMPATIBEL MED • СУМІСНИЙ З • YHTEENSOPIVA**

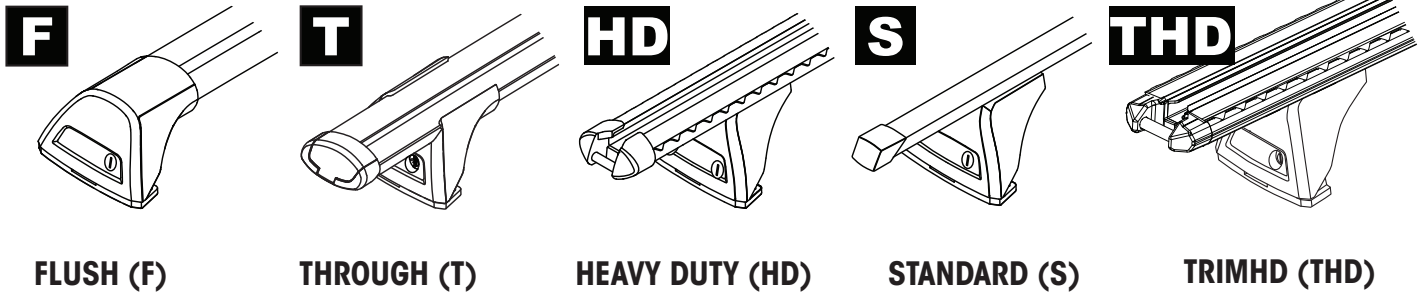

FLUSH (F)

THROUGH (T)

HEAVY DUTY (HD)

STANDARD (S)

TRIMHD (THD)

**ATTENTION • ACHTUNG • ATENCIÓN • ATTENTION • OPPMERKSOMHET • ATENÇÃO • ВНИМАНИЕ • ATTENZIONE
UWAGA • UPOZORNĚNÍ • UPOZORNENIE • LET OP • UPPMÄRKSAMHET • ОПМÆRKSOMHED • УВАГА • HUOMIO**

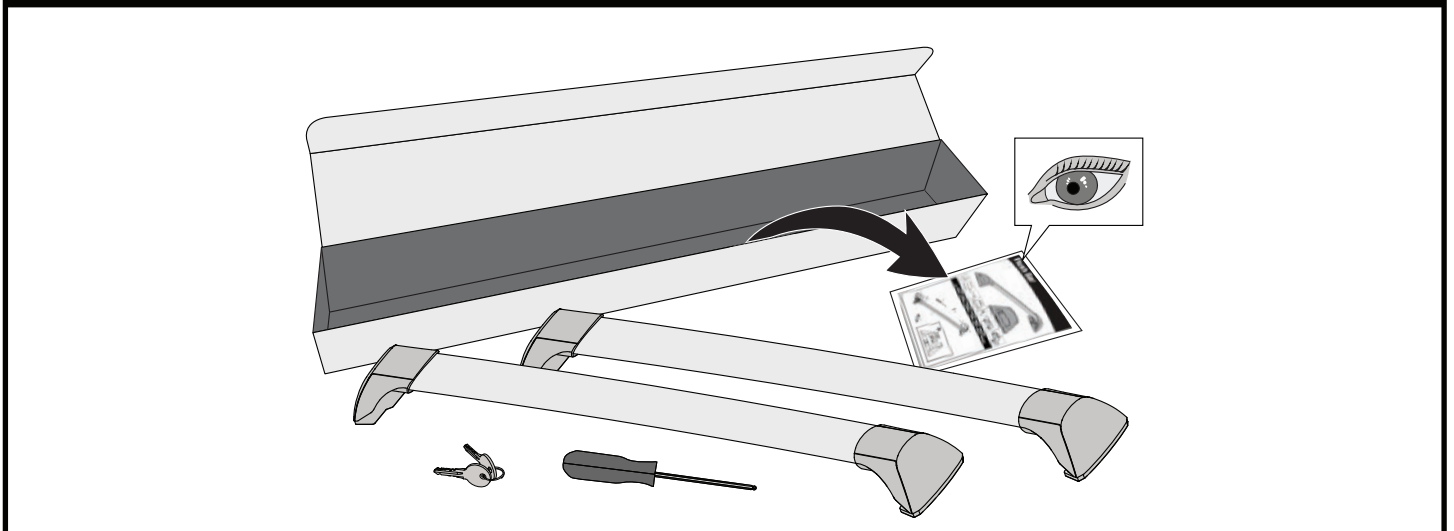

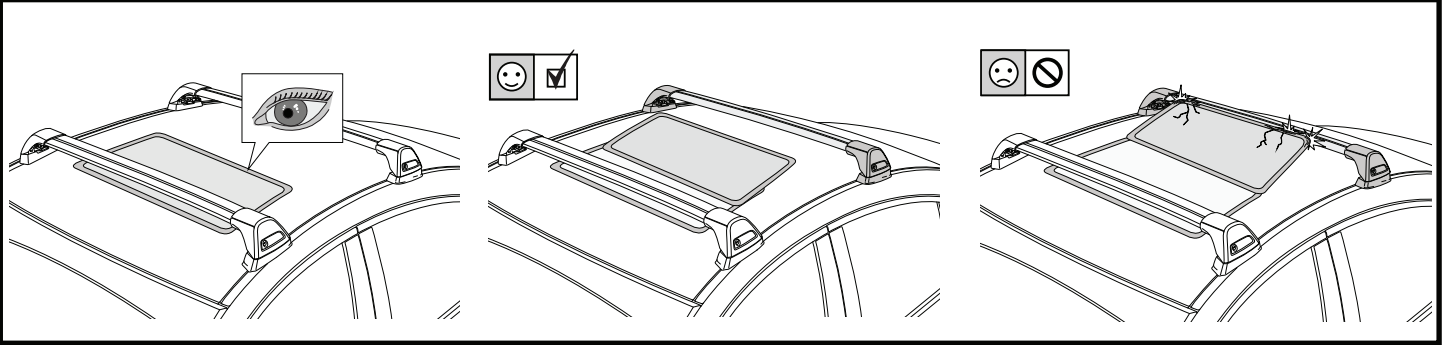

1

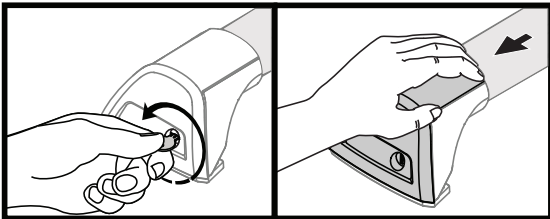

F

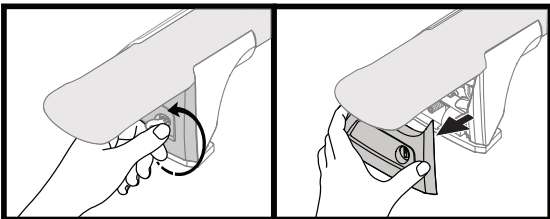
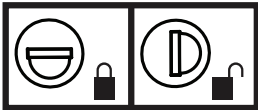

T

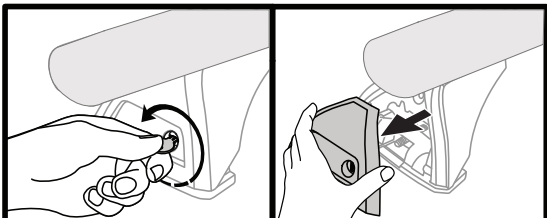
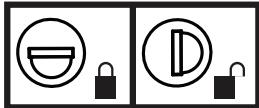

HD

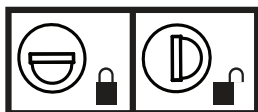

S

THD

x4

2

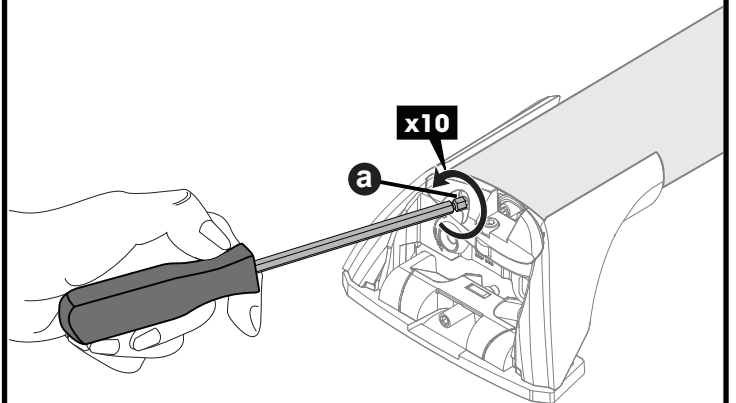
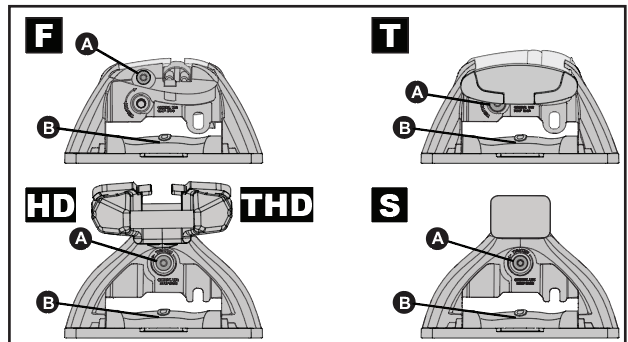
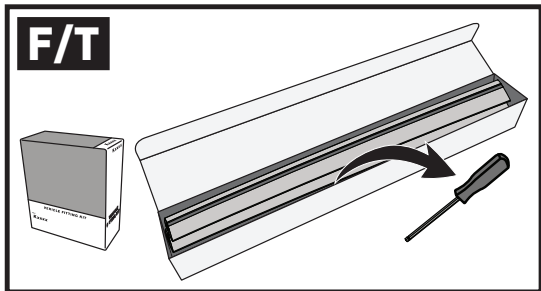
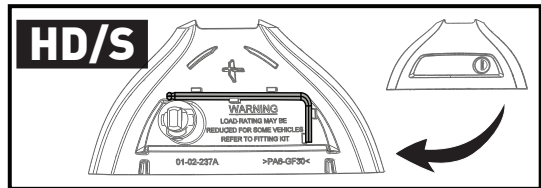

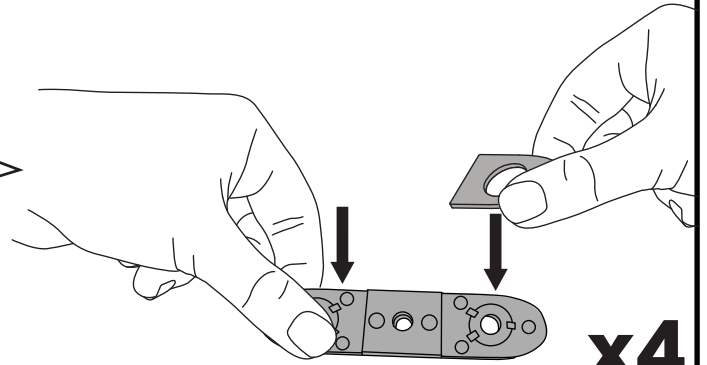
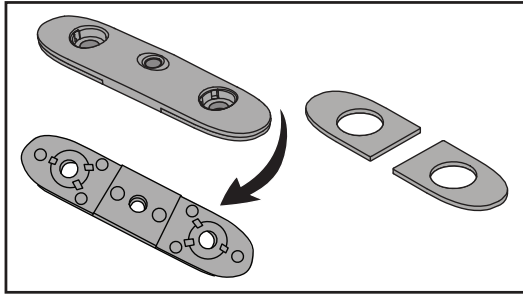

x4



3**x4**

**ATTENTION • ACHTUNG • ATENCIÓN • ATTENTION • OPPMERKSOMHET • ATENÇÃO • ВНИМАНИЕ • ATTENZIONE
 UWAGA • UPOZORNĚNÍ • UPOZORNENIE • LET OP • UPPMÄRKSAMHET • OPMÆRKSOMHED • УВАГА • HUOMIO**

**IONIQ 6 ONLY • IONIQ 6 NUR • IONIQ 6 SOLAMENTE • IONIQ 6 SEULEMENT • IONIQ 6 BARE • IONIQ 6 SOMENTE
 • IONIQ 6 ТОЛЬКО • SOLO IONIQ 6 • IONIQ 6 TYLKO • IONIQ 6 POUZE • IONIQ 6 IBA • IONIQ 6 ALLEEN • IONIQ 6 BARA
 • KUN IONIQ 6 • IONIQ 6 ТИЛЬКИ • VAIN IONIQ 6**



4

		A	B
Hyundai Ioniq 6, 4dr Sedan 23+	AU, EU, NZ	-A = 255 mm (10")	B = 430 mm (16 7/8")

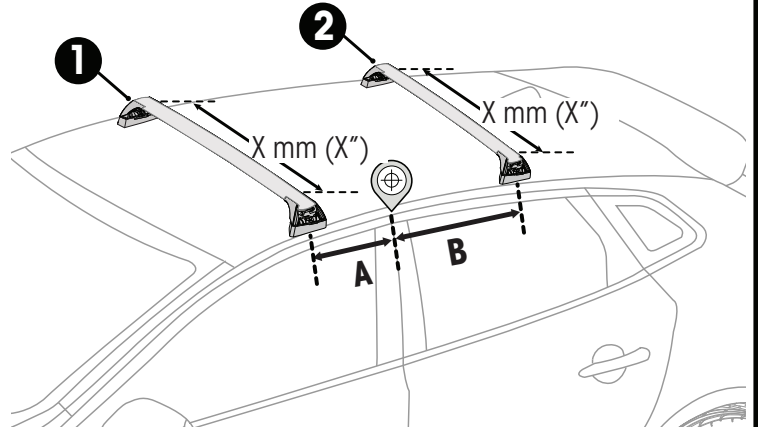
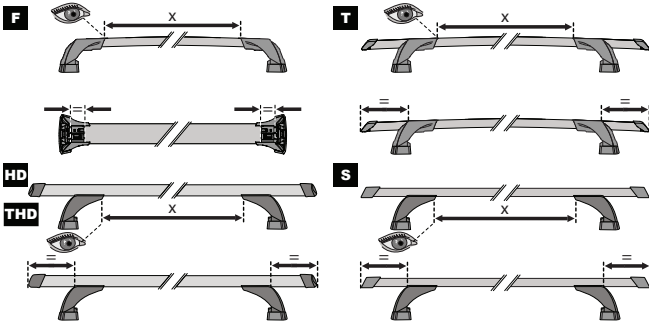
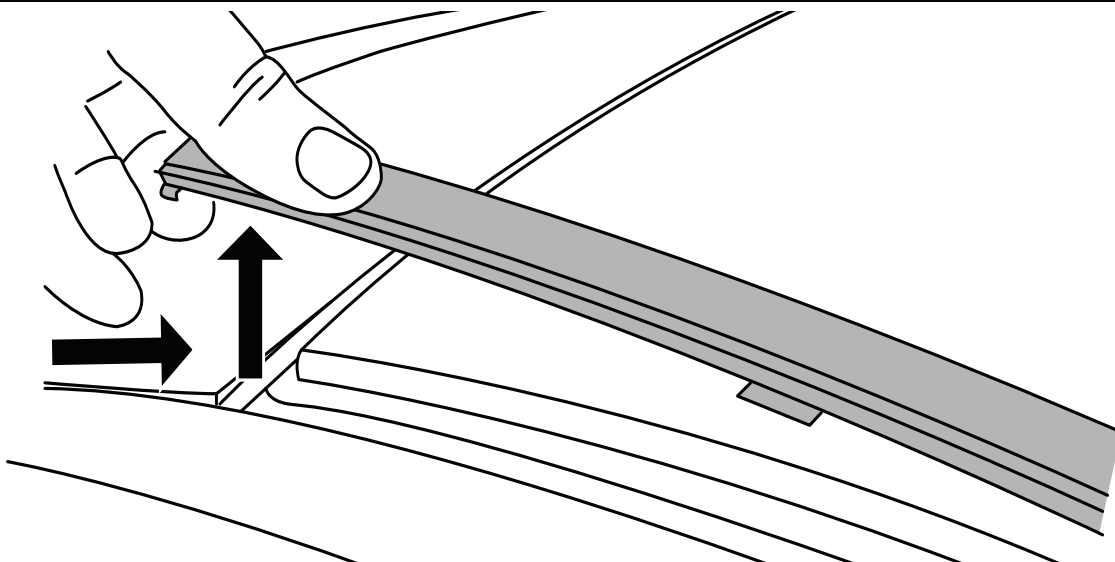
		1	2
Hyundai Ioniq 6, 4dr Sedan 23+	AU, EU, NZ	X = 940 mm (37")	X = 840 mm (33 1/8")

**1.****x4**

2.

		A	B
Hyundai Ioniq 6, 4dr Sedan 23+	AU, EU, NZ	-A = 255 mm (10")	B = 430 mm (16 7/8")

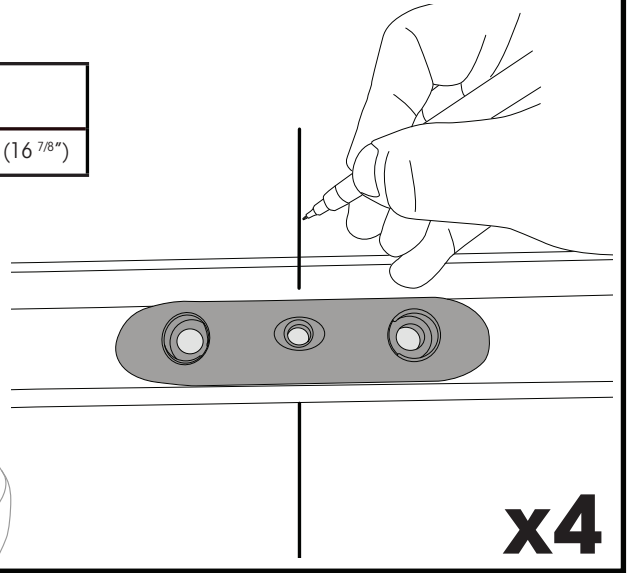
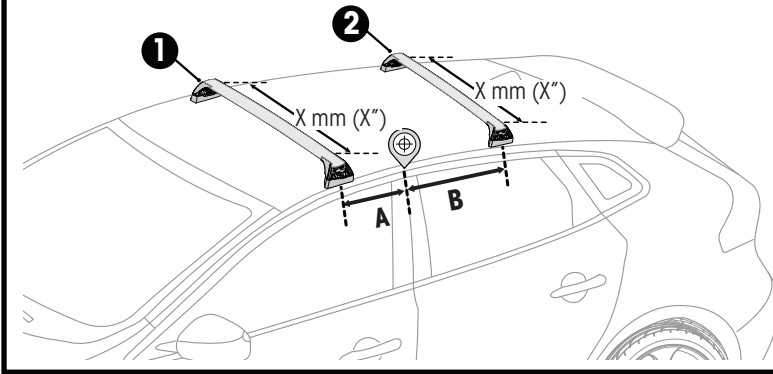

x4

3.

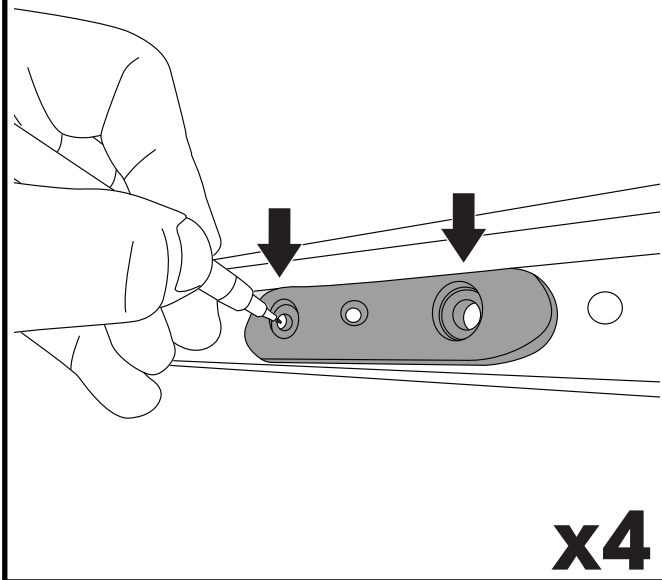

x4

4.

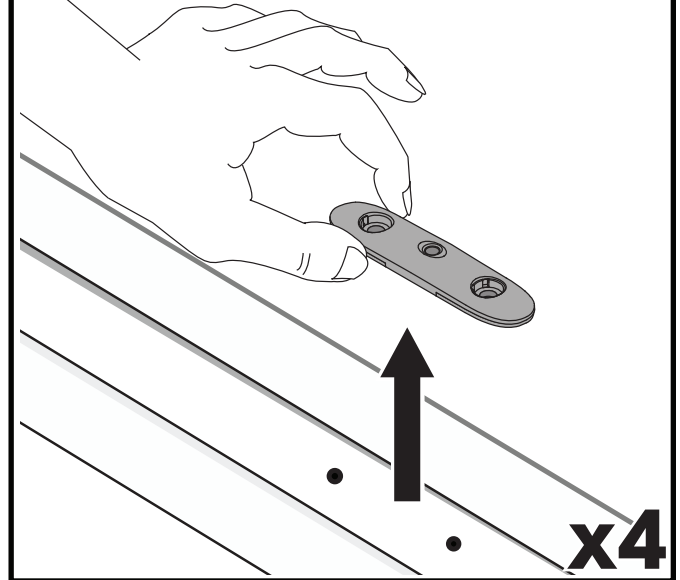

x4

5.

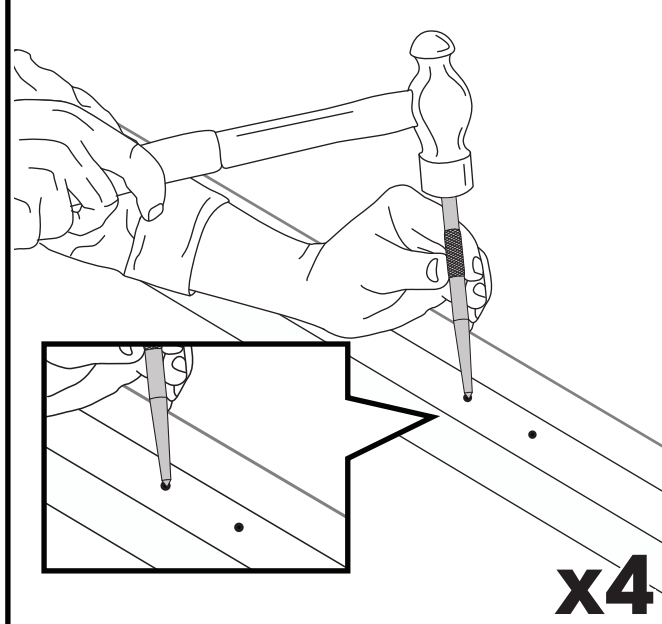

x4

6.

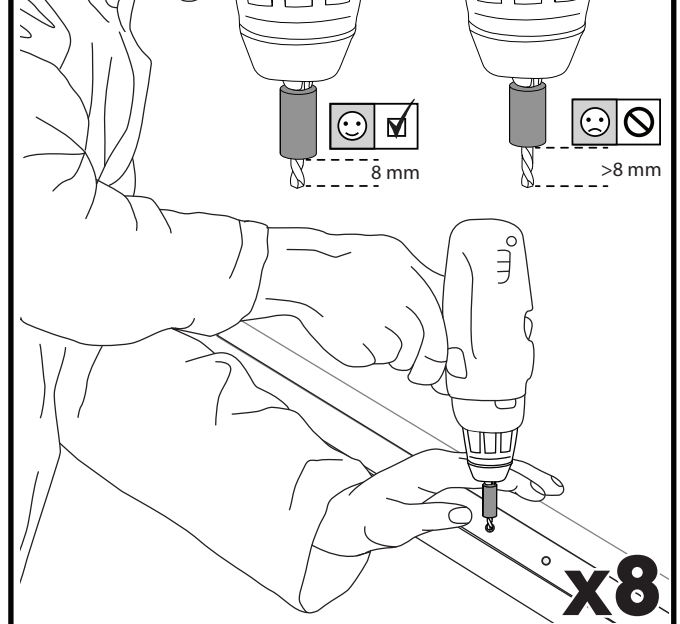

x8

7.

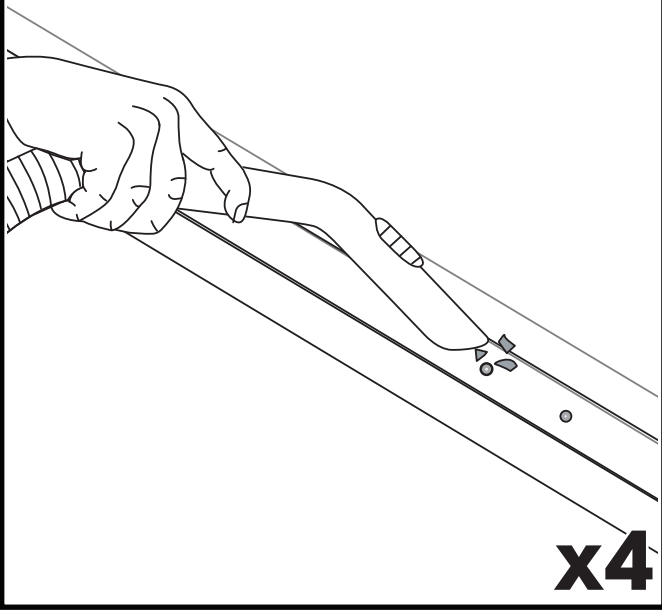

x4

8.

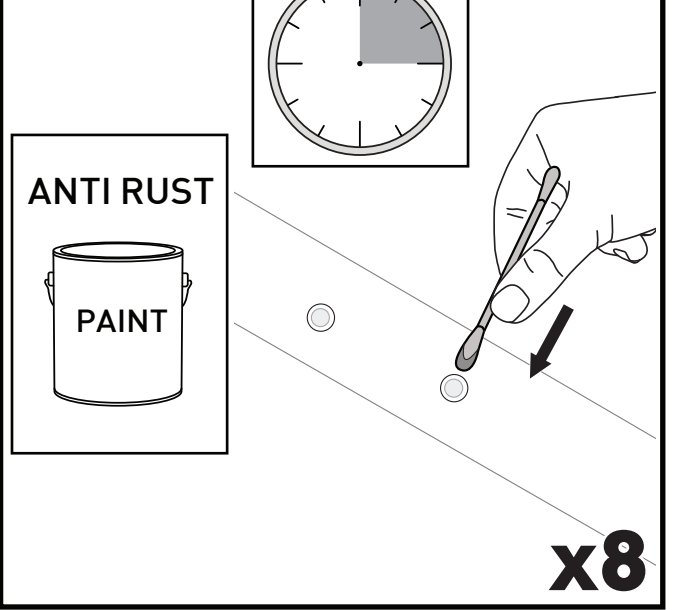

x8

9.

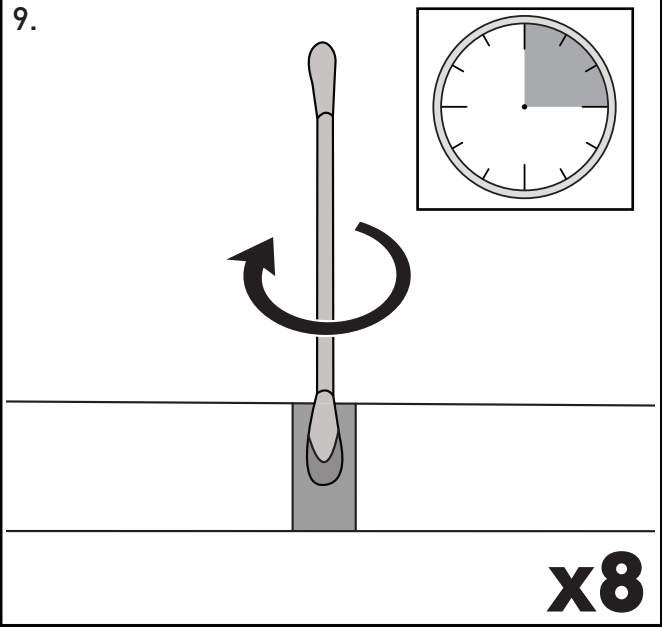

x8

10.

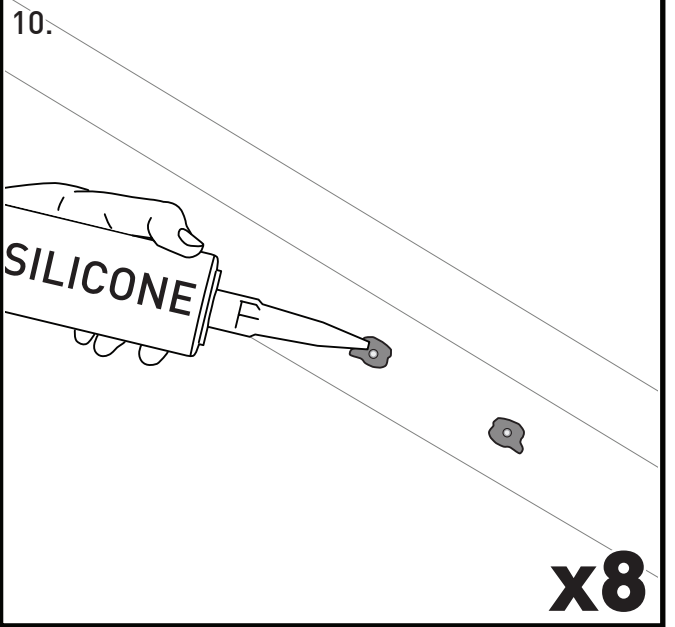

x8

11.

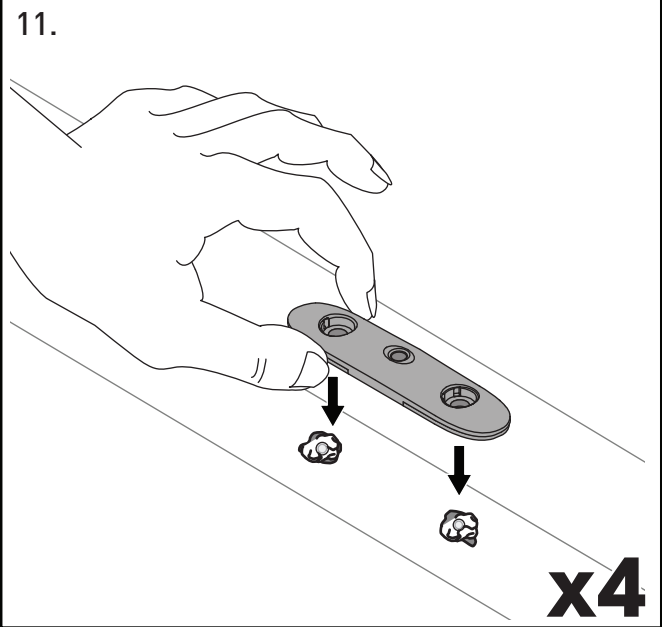

x4

12.

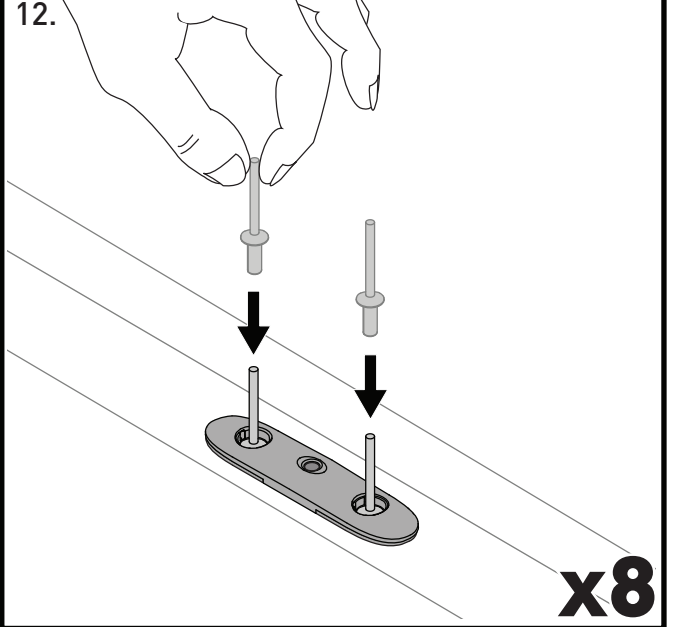



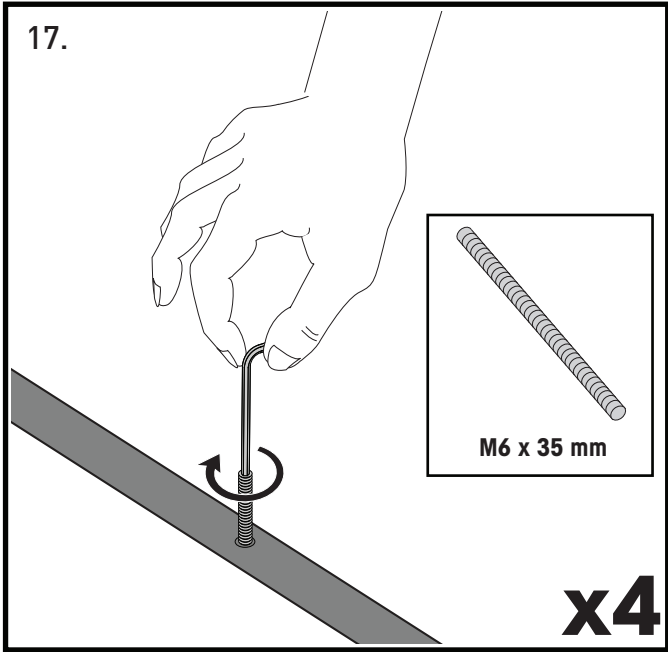
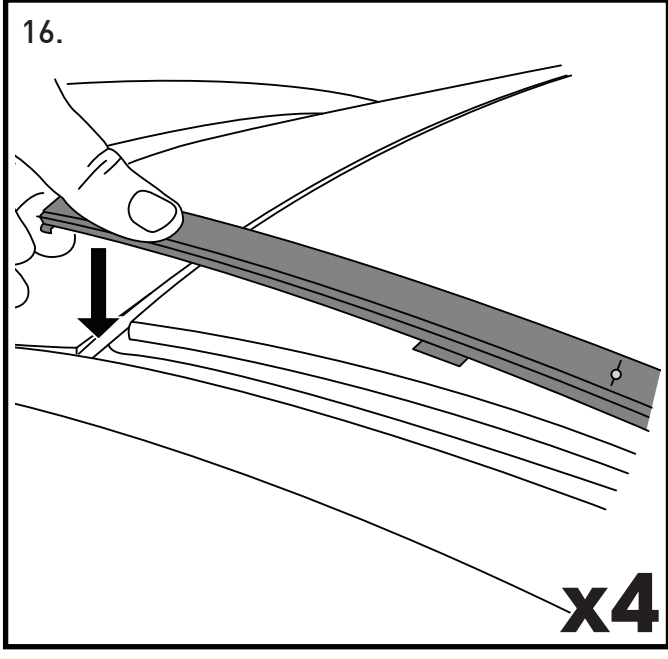
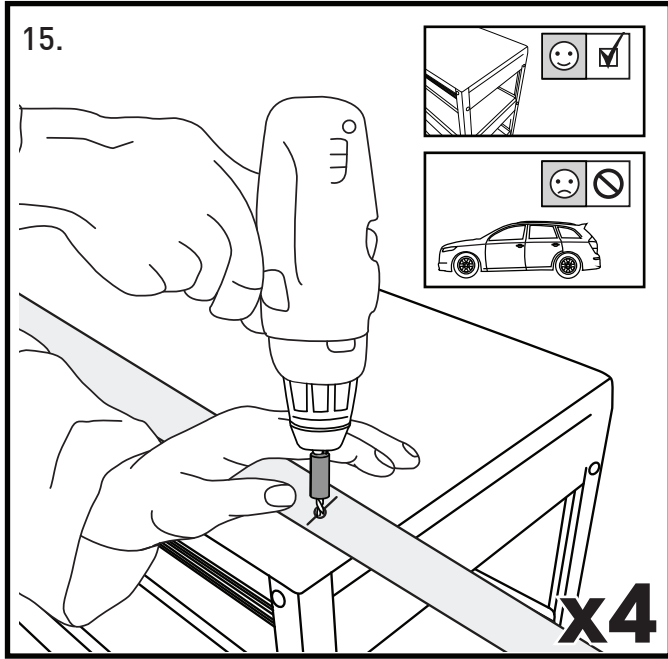
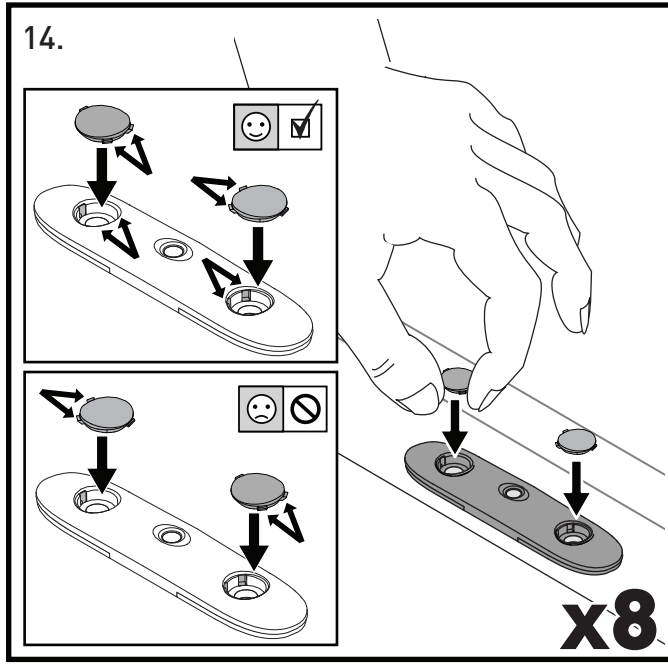
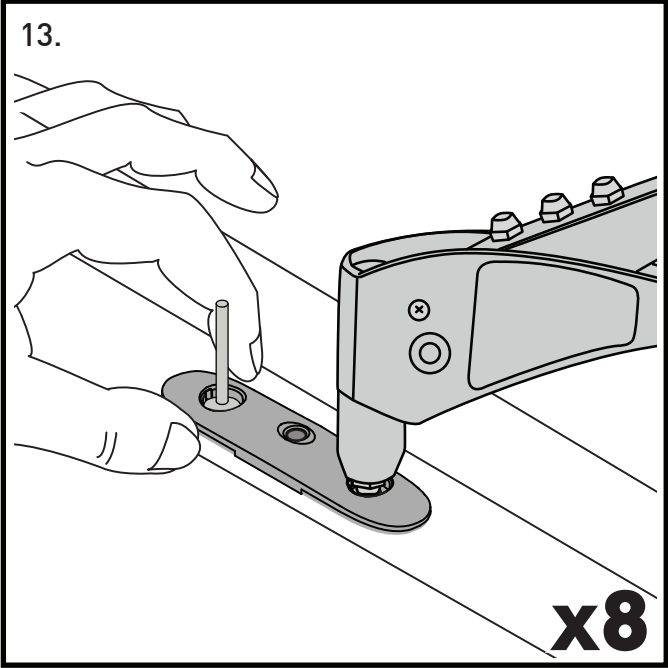

x8

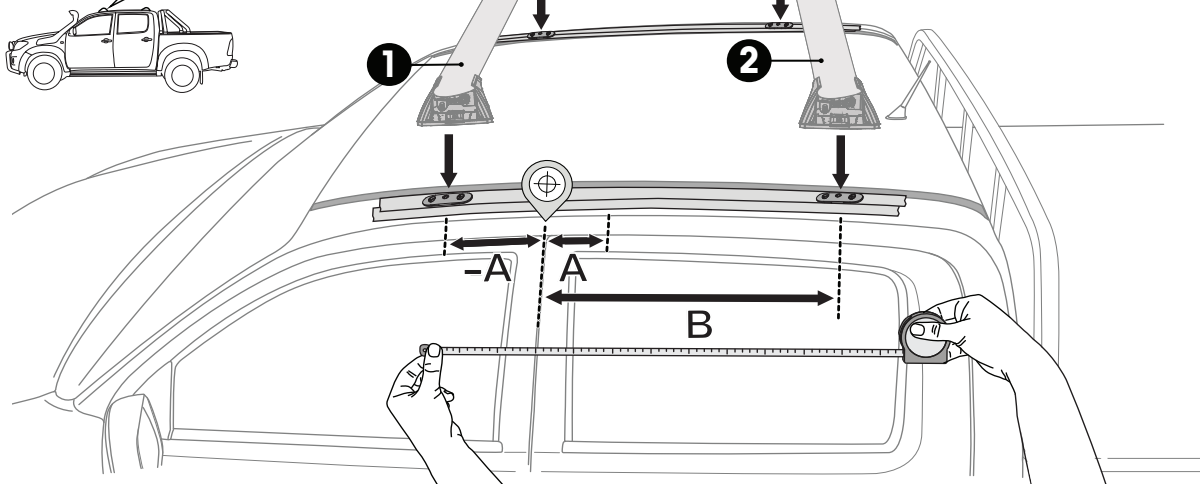
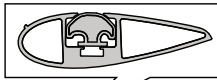
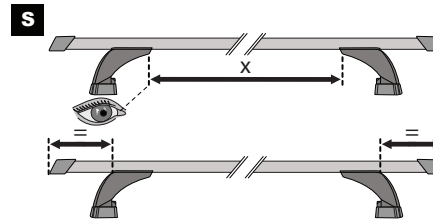
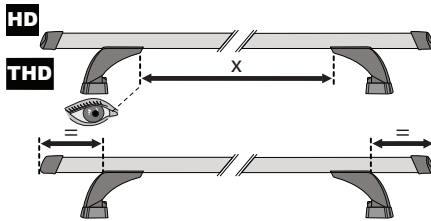
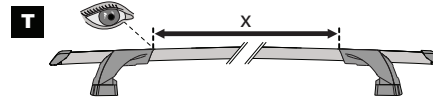
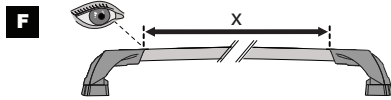
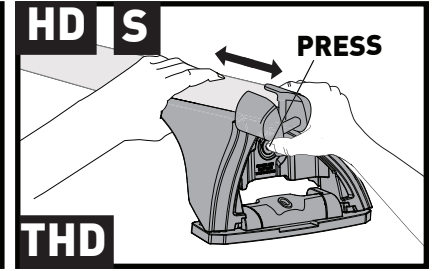
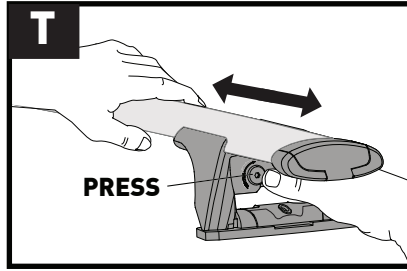
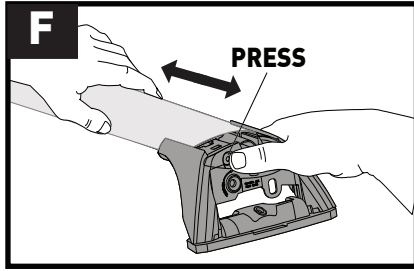

5



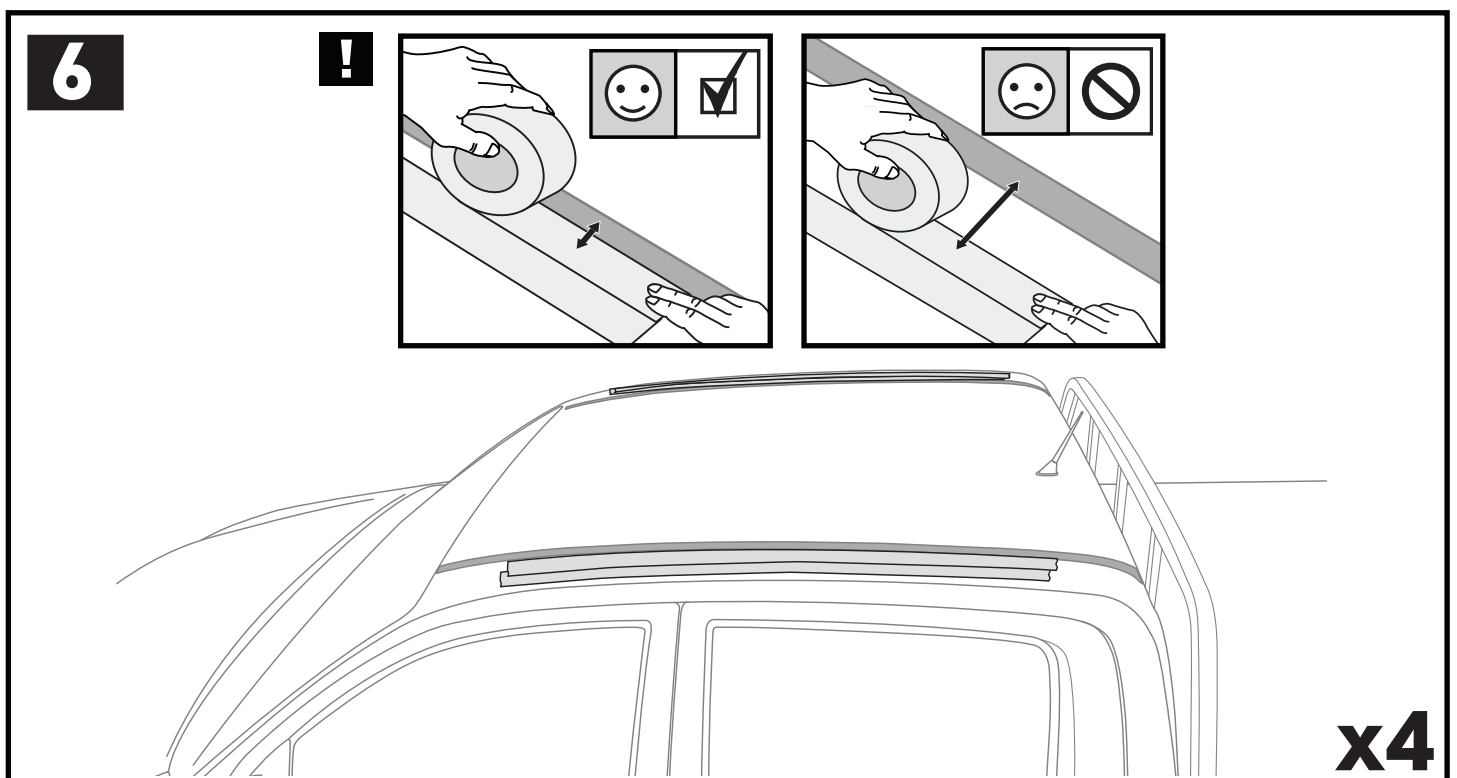

		1	2
Chevrolet Colorado Crew Cab, 4dr Ute 12-20	EU	X = 975 mm (38 3/8")	X = 960 mm (37 6/8")
Chevrolet Colorado Extended Cab, 4dr Ute 12+	EU	X = 985 mm (38 3/4")	X = 985 mm (38 3/4")
Chevrolet Colorado Single Cab, 2dr Ute 13-20	EU	X = 960 mm (37 6/8")	-
Dodge Ram 1500 Crew Cab DS, 4dr Ute 09-12	AU, NZ	X = 1085 mm (42 3/4")	X = 1085 mm (42 3/4")
Dodge Ram 1500 Crew Cab, 4dr Ute 09-12	EU	X = 1085 mm (42 3/4")	X = 1085 mm (42 3/4")
Dodge Ram 1500, Quad Cab 4dr Ute 09-12	AU, EU, NZ	X = 1085 mm (42 3/4")	X = 1085 mm (42 3/4")
Holden Colorado Single Cab, 2dr Ute 12-20	AU, NZ	X = 960 mm (37 6/8")	-
Holden Colorado Space Cab, 4dr Ute 12-20	AU, NZ	X = 985 mm (38 3/4")	X = 985 mm (38 3/4")
Isuzu D-Max SX Crew Cab, 4dr Ute 12-Aug 20	AU, NZ	X = 960 mm (37 6/8")	X = 960 mm (37 6/8")
Isuzu D-Max Extended Cab, 4dr Ute 12-20	EU	X = 960 mm (37 6/8")	X = 960 mm (37 6/8")
Isuzu D-Max Single Cab, 2dr Ute 12-19	EU	X = 975 mm (38 3/8")	-
Isuzu D-Max SX/EX Single Cab, 2dr Ute 12-Aug 20	AU, NZ	X = 960 mm (37 6/8")	X = 960 mm (37 6/8")

		1	2
Isuzu D-Max Single Cab, 2dr Ute 20+	EU	X = 975 mm (38 3/8")	-
Isuzu D-Max Single Cab, 2dr Ute Sep 20+	AU, NZ	X = 975 mm (38 3/8")	-
Isuzu D-Max LS-U/LS-M Space Cab, 4dr Ute 12-Aug 20	AU, NZ	X = 960 mm (37 6/8")	X = 960 mm (37 6/8")
Isuzu D-Max SX Space Cab, 4dr Ute May 12-Aug 20	AU, NZ	X = 960 mm (37 6/8")	X = 960 mm (37 6/8")
Isuzu D-Max Space Cab, 4dr Ute 20+	EU	X = 980 mm (38 5/8")	X = 975 mm (38 3/8")
Isuzu D-Max Space Cab, 4dr Ute Sep 20+	AU, NZ	X = 980 mm (38 5/8")	X = 975 mm (38 3/8")
Isuzu MU-X LS-M, 5dr SUV 21+	EU	X = 970 mm (38 1/4")	X = 960 mm (37 6/8")
Isuzu MU-X LS-M, 5dr SUV Aug 21+	AU, NZ	X = 970 mm (38 1/4")	X = 960 mm (37 6/8")
LDV Deliver 7, 5dr Van 24+	AU, EU, NZ	X = 1270 mm (50")	X = 1270 mm (50")
LDV e Deliver 7, 5dr Van 24+	AU, EU, NZ	X = 1270 mm (50")	X = 1270 mm (50")
LDV Deliver 9, 4dr Van Oct 20+	AU, NZ	X = 1425 mm (56 1/8")	X = 1430 mm (56 1/4")
LDV Maxus T90 EV, 4dr Ute 22+	EU	X = 985 mm (38 3/4")	X = 985 mm (38 3/4")
LDV T60/60 Max/eT60 Double Cab, 4dr Ute 17+	AU, NZ	X = 985 mm (38 3/4")	X = 985 mm (38 3/4")
LDV T60/60 Max/eT60 Single Cab, 4dr Ute Oct 17+	AU, NZ	X = 980 mm (38 5/8")	-
Mahindra Genio, 4dr Ute 14+	NZ	X = 1083 mm (42 5/8")	X = 1045 mm (41 1/8")
Mahindra Genio, 4dr Ute 16+	AU	X = 1083 mm (42 5/8")	X = 1045 mm (41 1/8")
Mazda BT-50 Freestyle Cab, 4dr Ute Oct 20+	AU, NZ	X = 970 mm (38 1/4")	X = 970 mm (38 1/4")
Mazda BT-50 Single Cab, 2dr Ute Oct 20+	AU, NZ	X = 965 mm (38")	-
Mitsubishi L200 Single Cab, 2dr Ute 15-23	EU	X = 920 mm (36 1/4")	-
Mitsubishi Triton Single Cab, 2dr Ute May 15-Jan 24	AU, NZ	X = 950 mm (37 3/8")	-
Mitsubishi Triton Single Cab, 2dr Ute 24+	EU	X = 1010 mm (39 3/4")	-
Mitsubishi Triton Single Cab, 2dr Ute Feb 24+	AU, NZ	X = 1010 mm (39 3/4")	-
RAM 1500 Crew Cab, 4dr Ute 13-18	EU	X = 1085 mm (42 3/4")	X = 1085 mm (42 3/4")
RAM 1500 Crew Cab/Classic Cab, 4dr Ute 13-18	AU, NZ	X = 1085 mm (42 3/4")	X = 1085 mm (42 3/4")
RAM 1500 Quad Cab, 4dr Ute 13+	AU, EU, NZ	X = 1085 mm (42 3/4")	X = 1085 mm (42 3/4")
RAM 1500, 4dr Ute 19+	AU	X = 1040 mm (41")	X = 1045 mm (41 1/8")
RAM 1500, 4dr Ute 20+	EU, NZ	X = 1040 mm (41")	X = 1045 mm (41 1/8")
RAM 2500 Crew Cab DT, 4dr Ute 20+	AU, EU, NZ	X = 1075 mm (42 3/8")	X = 1075 mm (42 3/8")

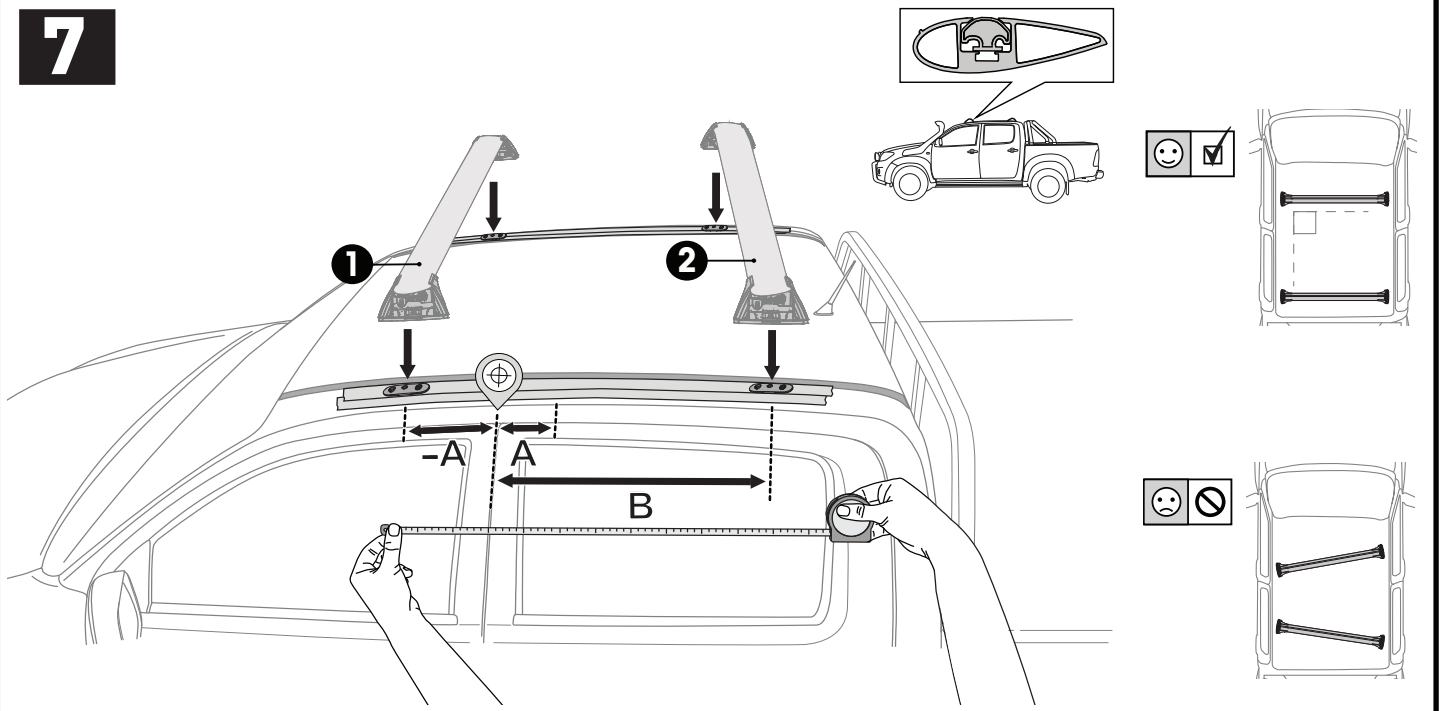

7



		A	B
Chevrolet Colorado Crew Cab, 4dr Ute 12-20	EU	-A = 200 mm (27 1/2")	B = 500 mm (19 5/8")
Chevrolet Colorado Extended Cab, 4dr Ute 12+	EU	-A = 280 mm (11")	B = 400 mm (15 3/4")
Chevrolet Colorado Single Cab, 2dr Ute 13-20	EU	-A = 200 mm (27 1/2")	-
Dodge Ram 1500 Crew Cab DS, 4dr Ute 09-12	AU, NZ	-A = 150 mm (5 7/8")	B = 600 mm (23 5/8")
Dodge Ram 1500 Crew Cab, 4dr Ute 09-12	EU	-A = 150 mm (5 7/8")	B = 600 mm (23 5/8")
Dodge Ram 1500, Quad Cab 4dr Ute 09-12	AU, EU, NZ	-A = 150 mm (5 7/8")	B = 500 mm (19 5/8")
Holden Colorado Single Cab, 2dr Ute 12-20	AU, NZ	-A = 200 mm (27 1/2")	-
Holden Colorado Space Cab, 4dr Ute 12-20	AU, NZ	-A = 280 mm (11")	B = 400 mm (15 3/4")
Isuzu D-Max SX Crew Cab, 4dr Ute 12-Aug 20	AU, NZ	-A = 200 mm (27 1/2")	B = 500 mm (19 5/8")
Isuzu D-Max Extended Cab, 4dr Ute 12-20	EU	-A = 300 mm (11 3/4")	B = 345 mm (13 5/8")
Isuzu D-Max Single Cab, 2dr Ute 12-19	EU	-A = 200 mm (27 1/2")	-
Isuzu D-Max SX/EX Single Cab, 2dr Ute 12-Aug 20	AU, NZ	-A = 200 mm (27 1/2")	-
Isuzu D-Max Single Cab, 2dr Ute 20+	EU	-A = 200 mm (27 1/2")	-
Isuzu D-Max Single Cab, 2dr Ute Sep 20+	AU, NZ	-A = 200 mm (27 1/2")	-
Isuzu D-Max LS-U/LS-M Space Cab, 4dr Ute 12-Aug 20	AU, NZ	-A = 300 mm (11 3/4")	B = 345 mm (13 5/8")
Isuzu D-Max SX Space Cab, 4dr Ute May 12-Aug 20	AU, NZ	-A = 280 mm (11")	B = 400 mm (15 3/4")
Isuzu D-Max Space Cab, 4dr Ute 20+	EU	-A = 300 mm (11 3/4")	B = 345 mm (13 5/8")
Isuzu D-Max Space Cab, 4dr Ute Sep 20+	AU, NZ	-A = 300 mm (11 3/4")	B = 345 mm (13 5/8")
Isuzu MU-X LS-M, 5dr SUV 21+	EU	-A = 100 mm (3 7/8")	B = 550 mm (21 5/8")
Isuzu MU-X LS-M, 5dr SUV Aug 21+	AU, NZ	-A = 100 mm (3 7/8")	B = 550 mm (21 5/8")
LDV Deliver 7, 5dr Van 24+	AU, EU, NZ	-A = 150 mm (5 7/8")	B = 600 mm (23 5/8")
LDV e Deliver 7, 5dr Van 24+	AU, EU, NZ	-A = 150 mm (5 7/8")	B = 600 mm (23 5/8")
LDV Deliver 9, 4dr Van Oct 20+	AU, NZ	A = 840 mm (33 1/8")	B = 1835 mm (72 1/4")
LDV Maxus T90 EV, 4dr Ute 22+	EU	-A = 120 mm (4 3/4")	B = 620 mm (24 3/8")
LDV T60/60 Max/eT60 Double Cab, 4dr Ute 17+	AU, NZ	-A = 120 mm (4 3/4")	B = 620 mm (24 3/8")
LDV T60/60 Max/eT60 Single Cab, 4dr Ute Oct 17+	AU, NZ	-A = 260 mm (10 1/4")	-
Mahindra Genio, 4dr Ute 14+	NZ	-A = 40 mm (1 5/8")	B = 660 mm (26")
Mahindra Genio, 4dr Ute 16+	AU	-A = 40 mm (1 5/8")	B = 660 mm (26")
Mazda BT-50 Freestyle Cab, 4dr Ute Oct 20+	AU, NZ	-A = 330 mm (13")	B = 330 mm (13")
Mazda BT-50 Single Cab, 2dr Ute Oct 20+	AU, NZ	-A = 230 mm (9")	-

		A	B
Mitsubishi L200 Single Cab, 2dr Ute 15-23	EU	-A = 135 mm (5 3/8")	-
Mitsubishi Triton Single Cab, 2dr Ute May 15-Jan 24	AU, NZ	-A = 135 mm (5 3/8")	-
Mitsubishi Triton Single Cab, 2dr Ute 24+	EU	-A = 100 mm (3 7/8")	-
Mitsubishi Triton Single Cab, 2dr Ute Feb 24+	AU, NZ	-A = 100 mm (3 7/8")	-
RAM 1500 Crew Cab, 4dr Ute 13-18	EU	-A = 150 mm (5 7/8")	B = 600 mm (23 5/8")
RAM 1500 Crew Cab/Classic Cab, 4dr Ute 13-18	AU, NZ	-A = 150 mm (5 7/8")	B = 600 mm (23 5/8")
RAM 1500 Quad Cab, 4dr Ute 13+	AU, EU, NZ	-A = 150 mm (5 7/8")	B = 500 mm (19 5/8")
RAM 1500, 4dr Ute 19+	AU	-A = 150 mm (5 7/8")	B = 600 mm (23 5/8")
RAM 1500, 4dr Ute 20+	EU, NZ	-A = 150 mm (5 7/8")	B = 600 mm (23 5/8")
RAM 2500 Crew Cab DT, 4dr Ute 20+	AU, EU, NZ	-A = 150 mm (5 7/8")	B = 600 mm (23 5/8")

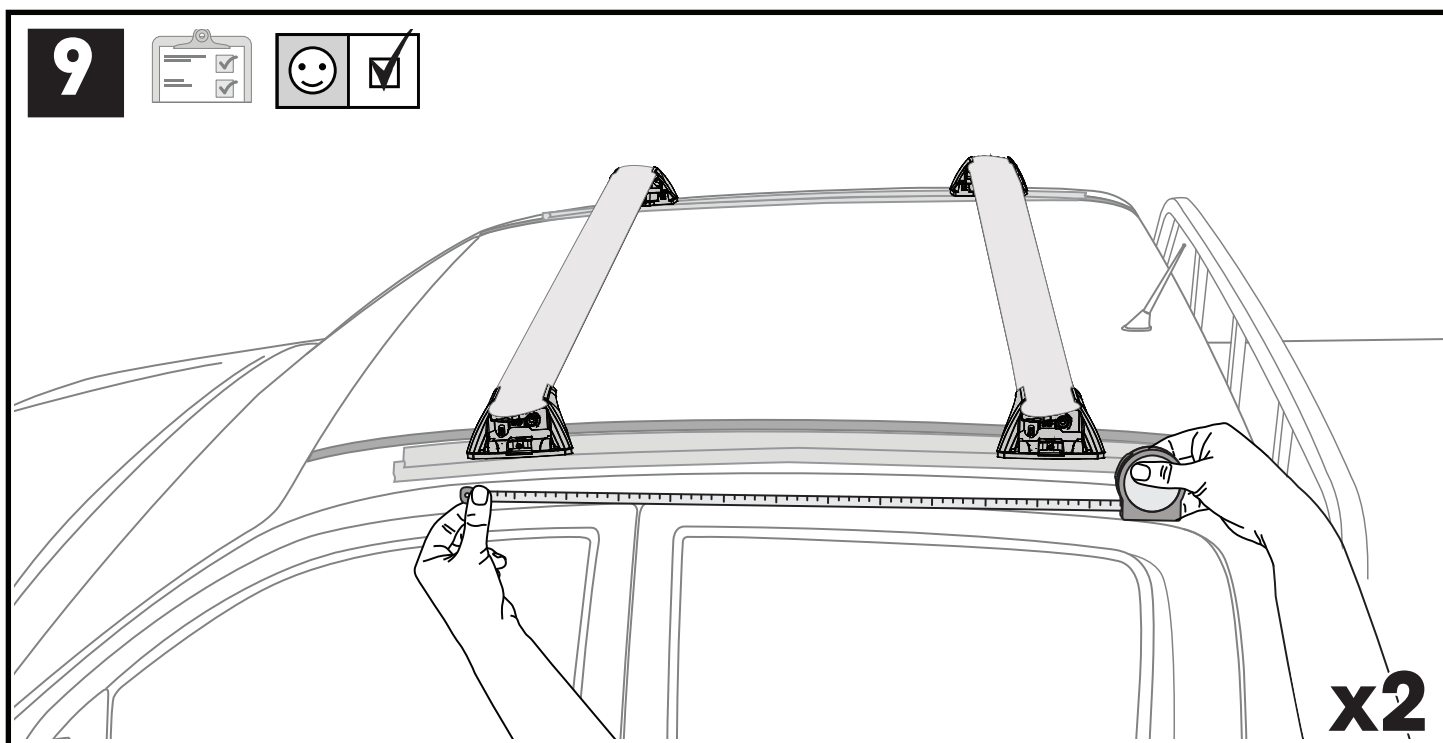
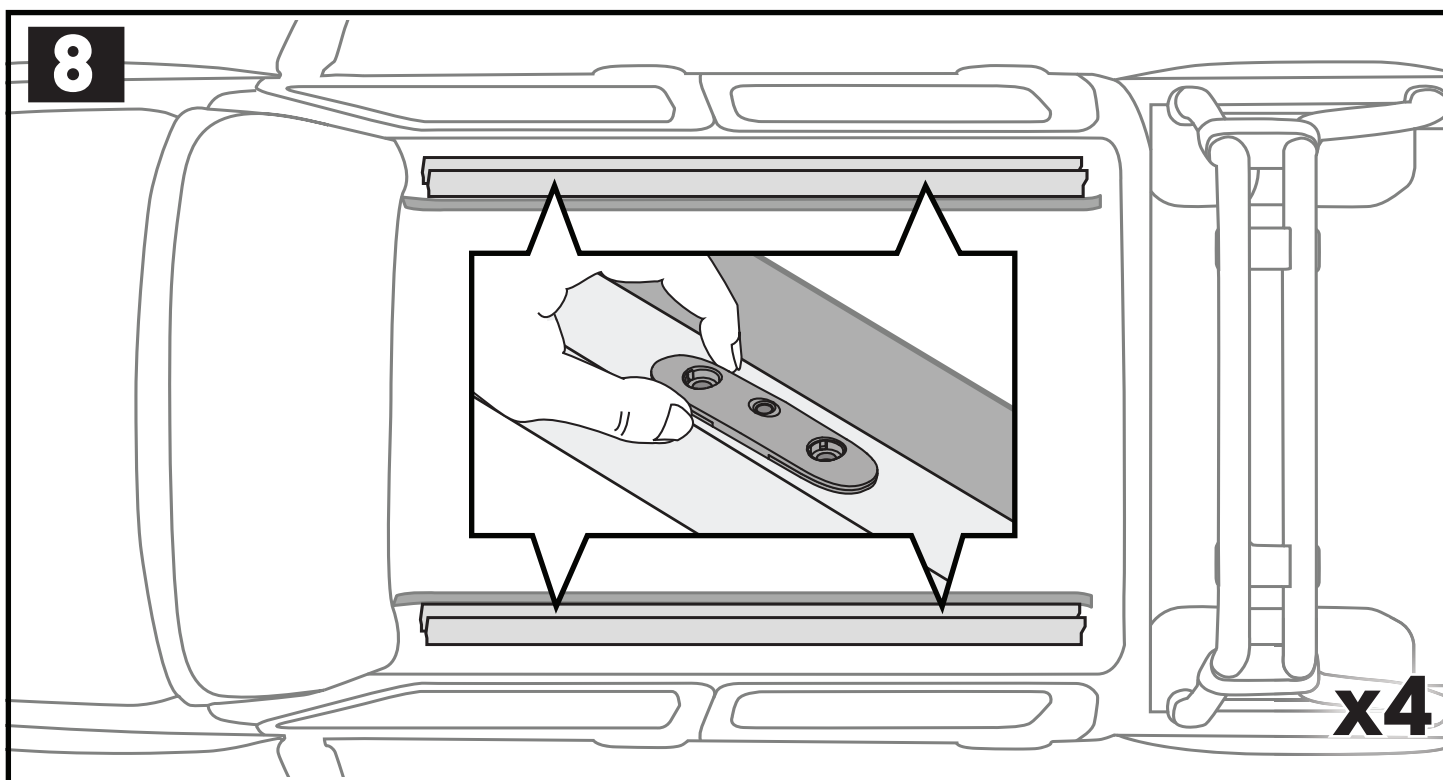

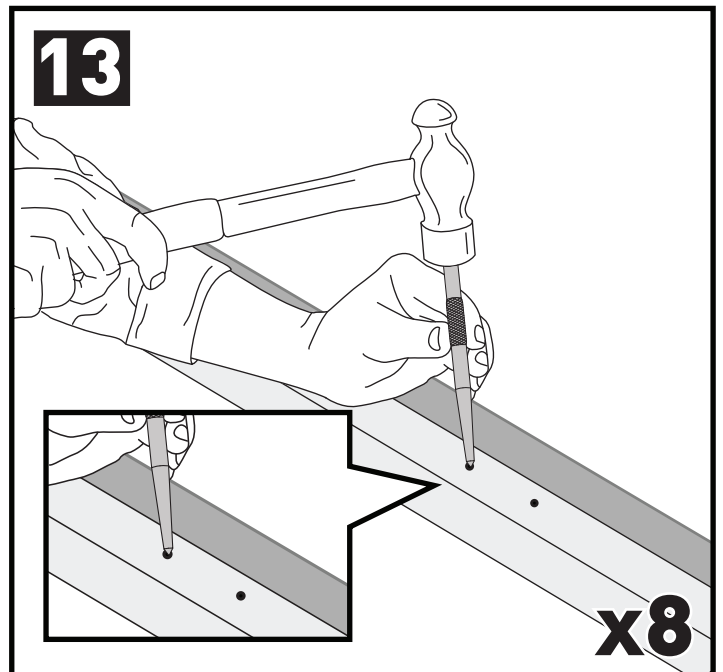
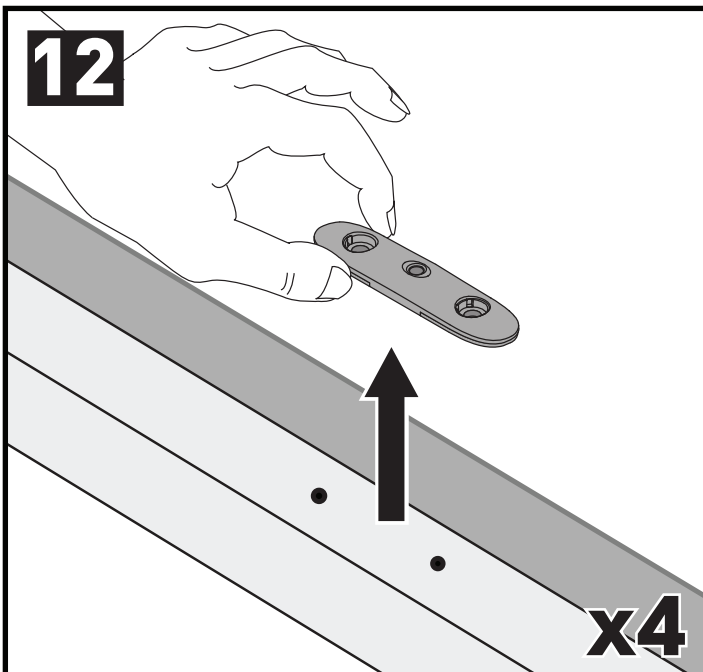
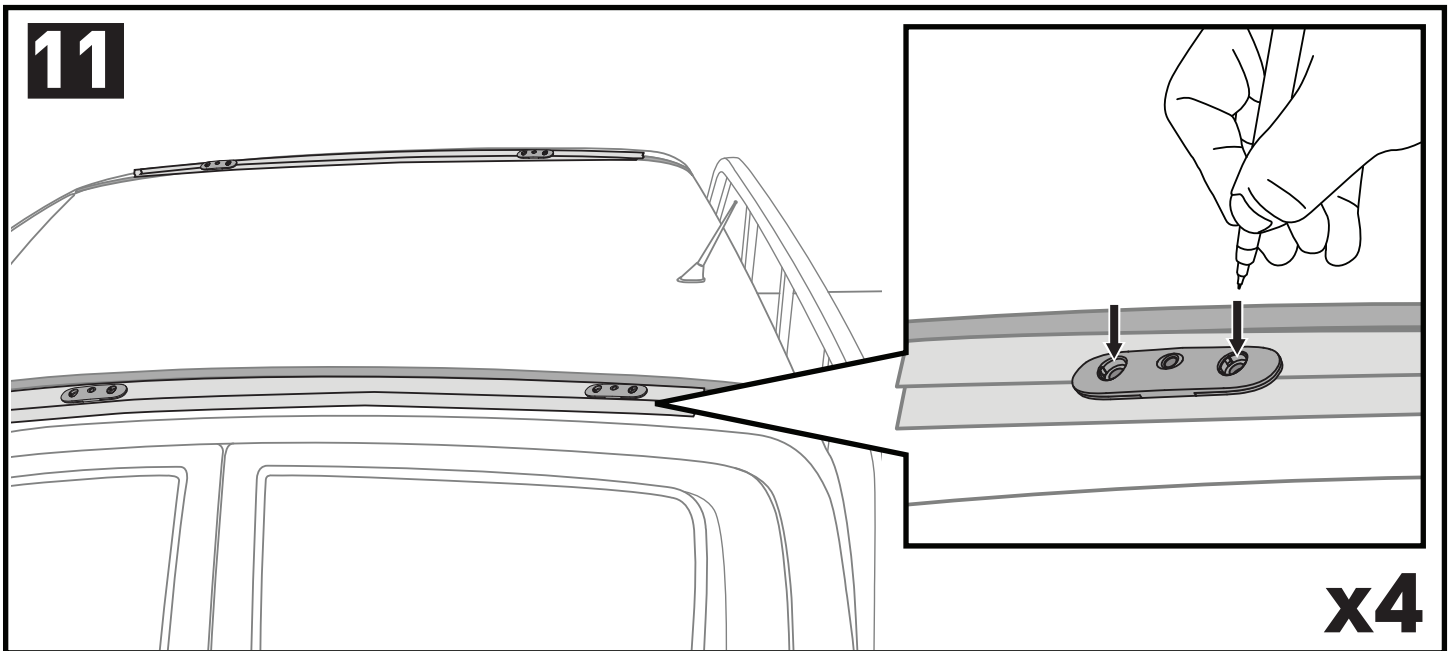
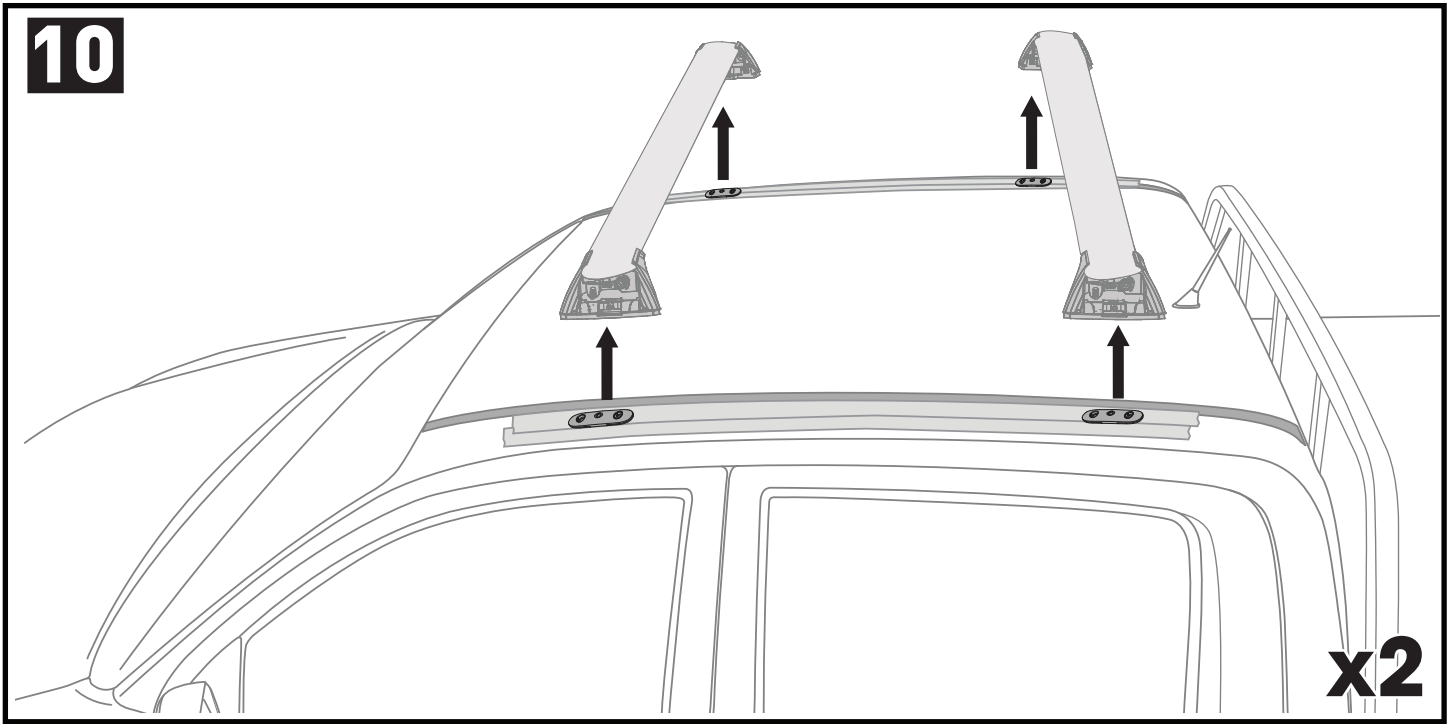

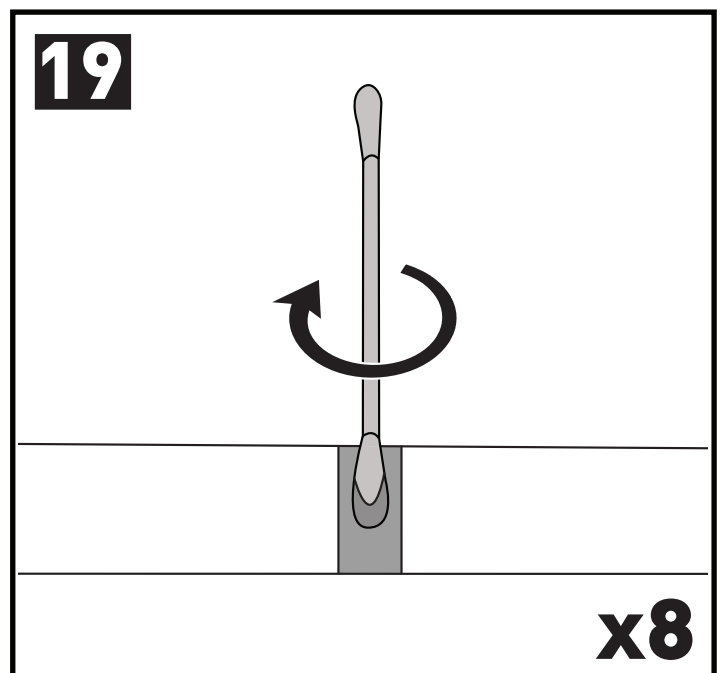
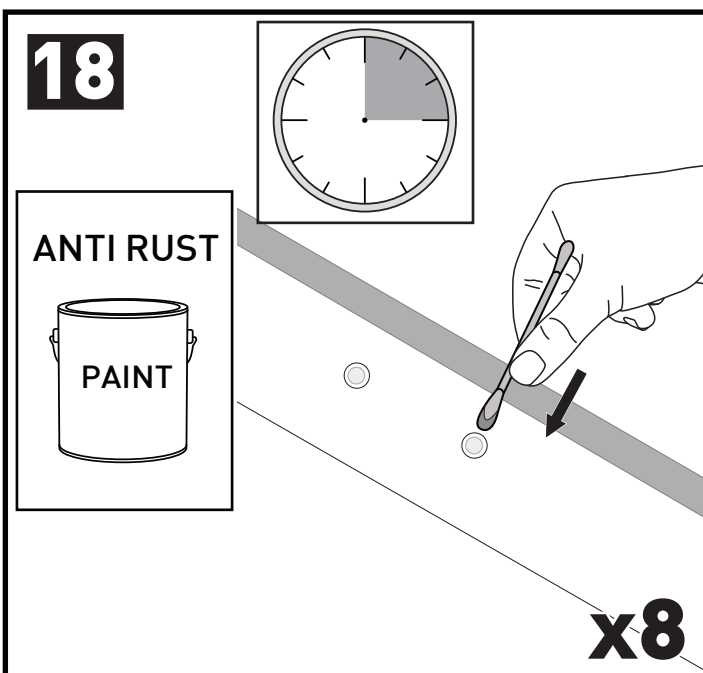
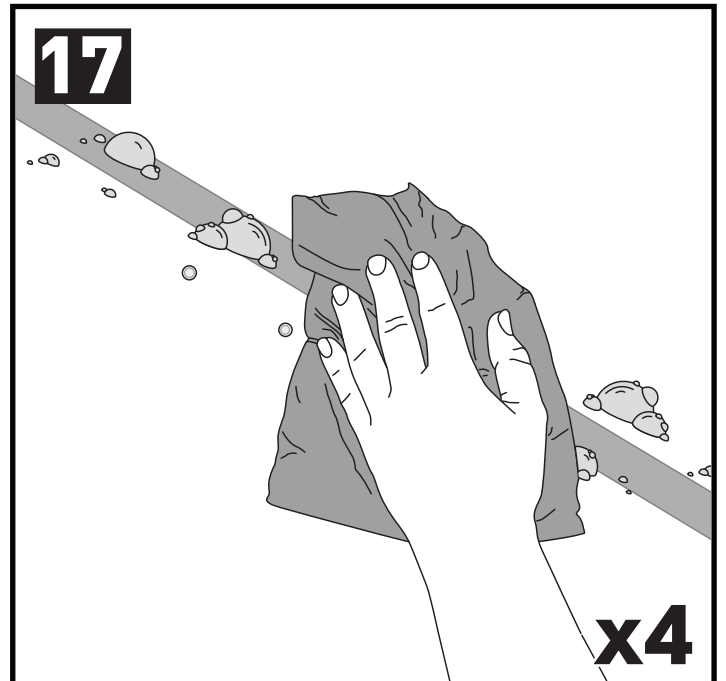
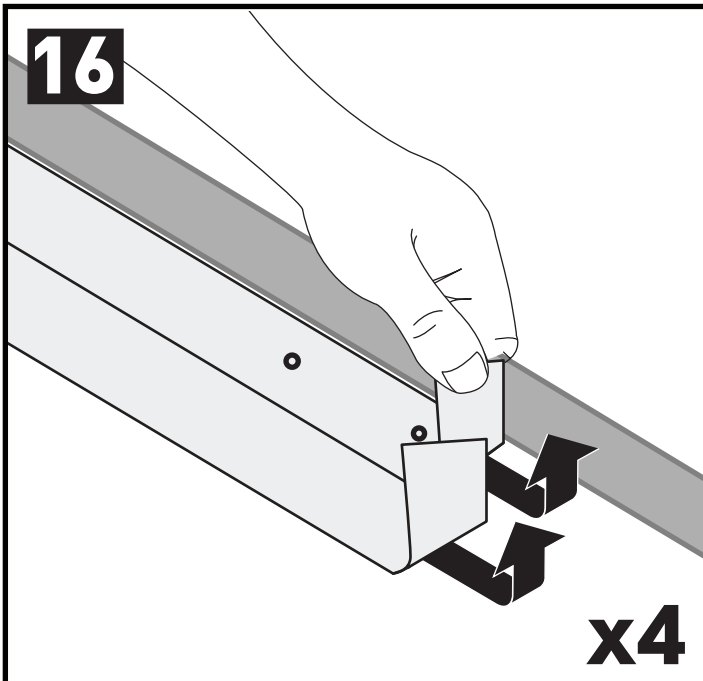
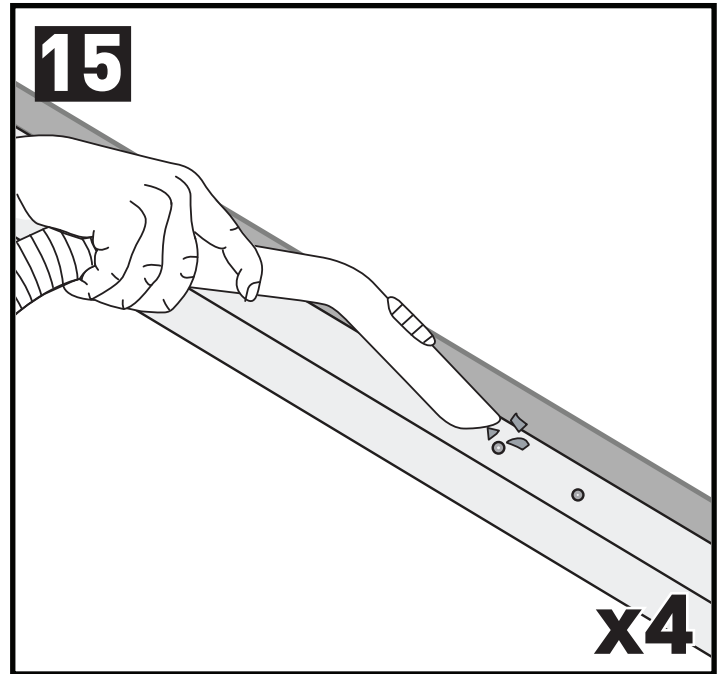
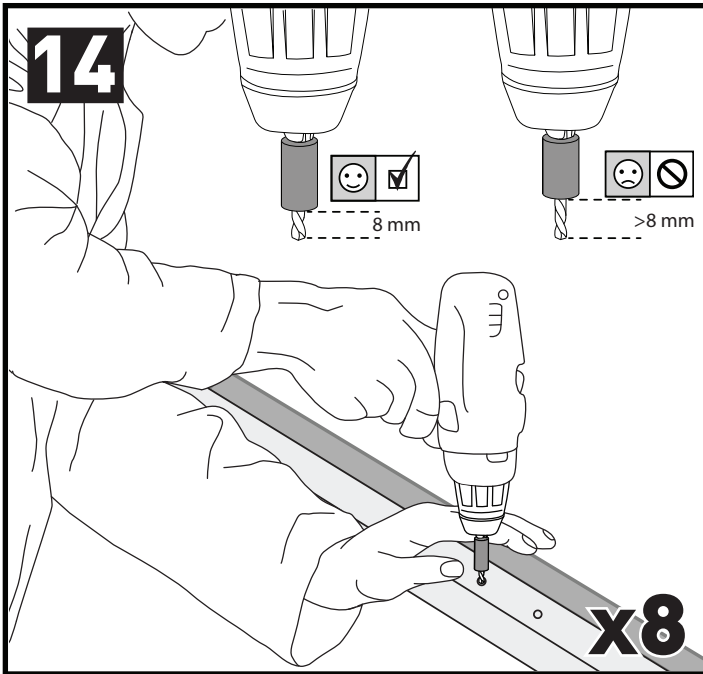

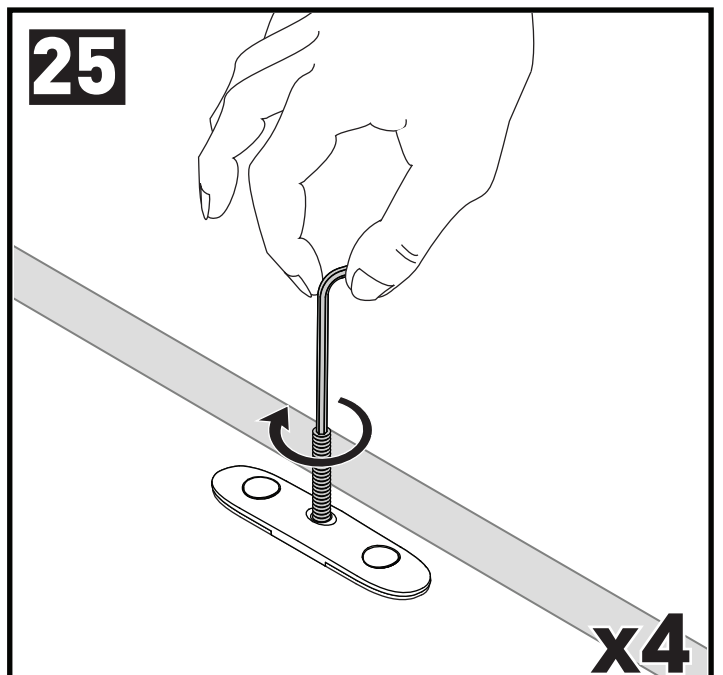
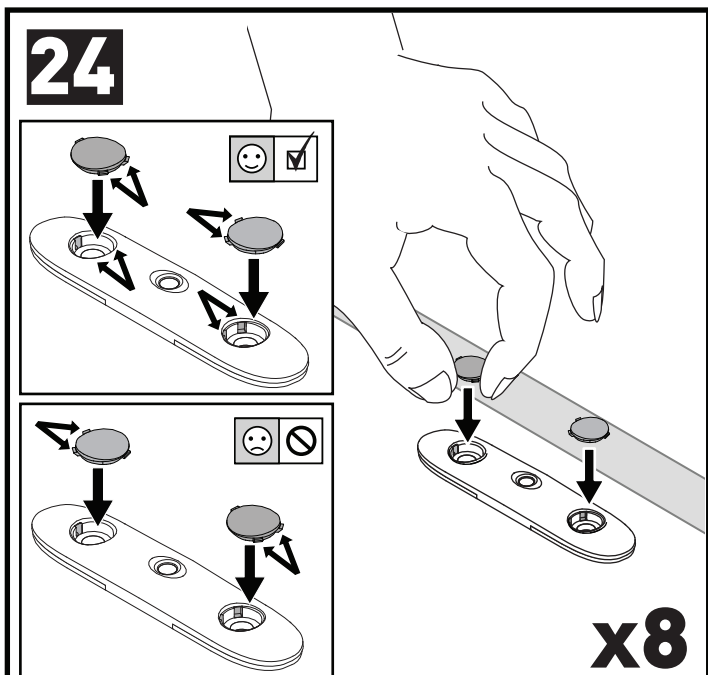
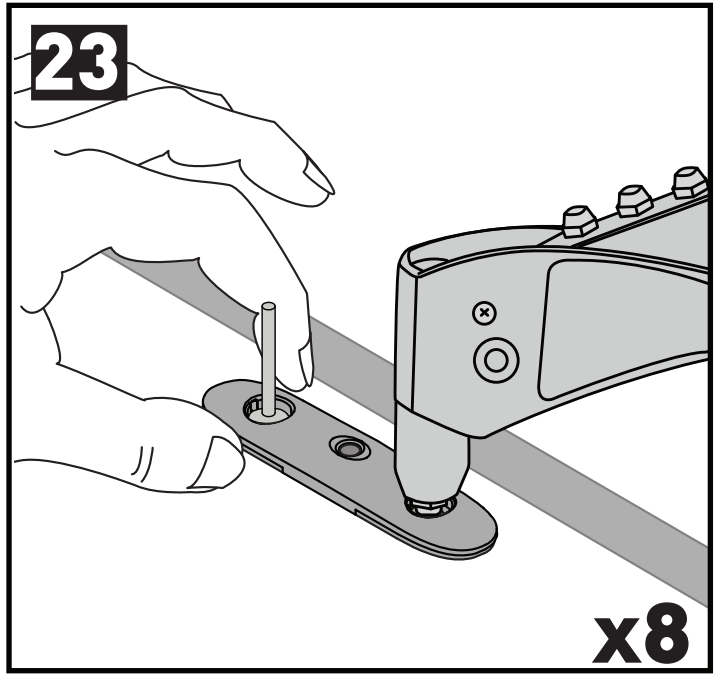
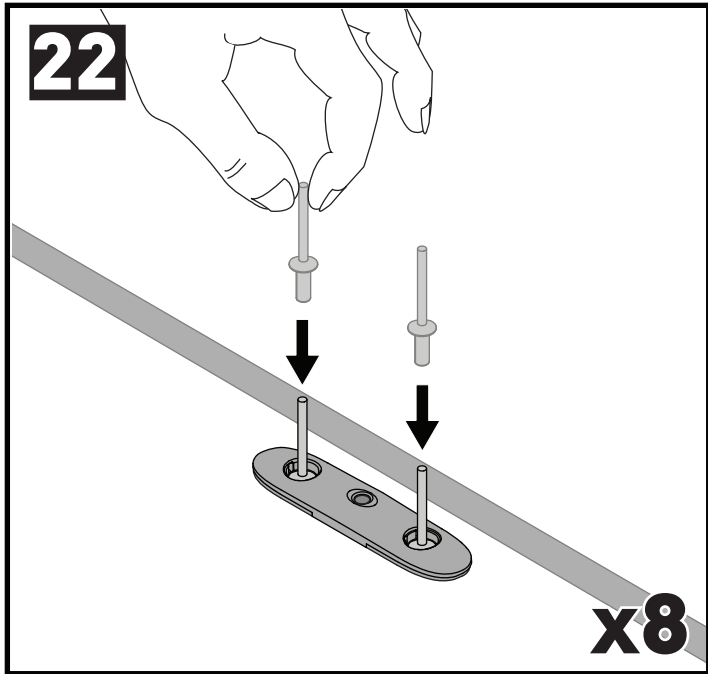
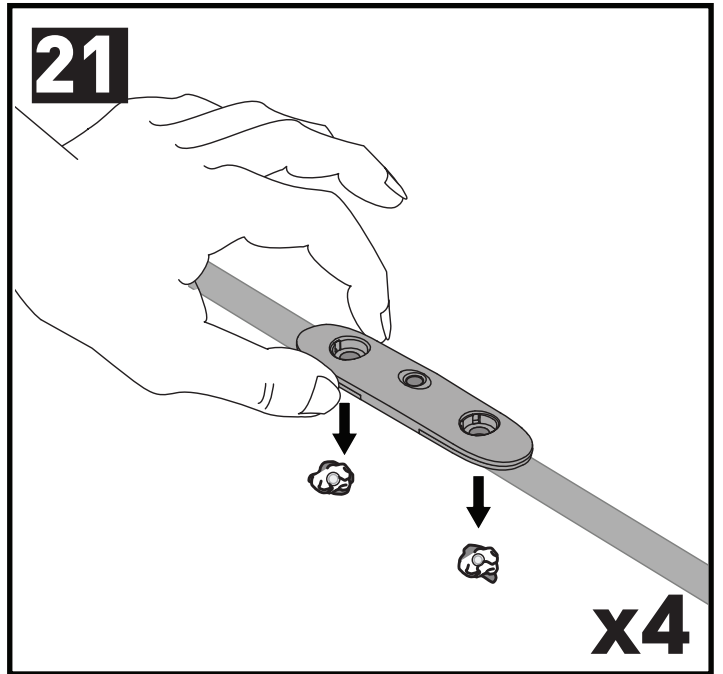
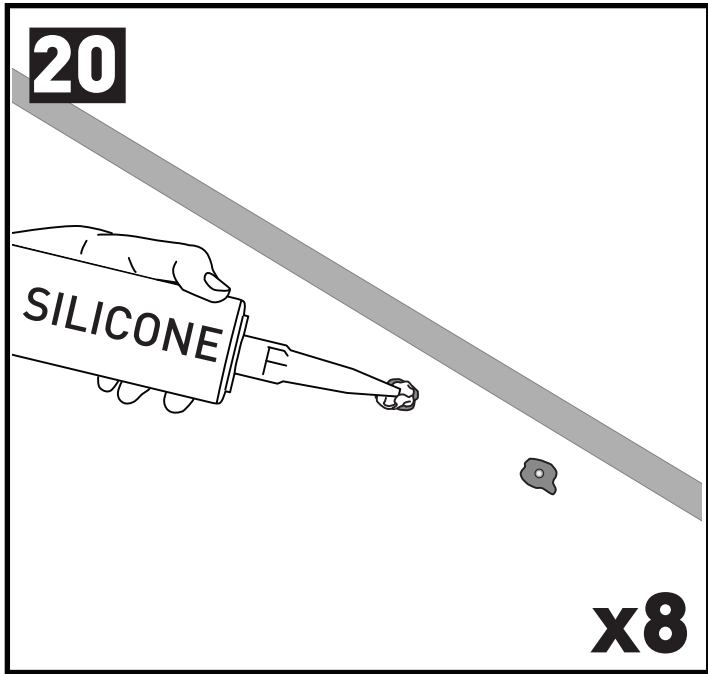

26

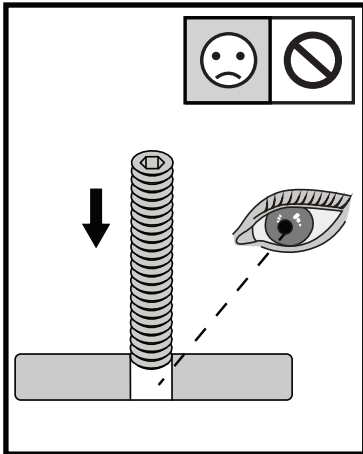
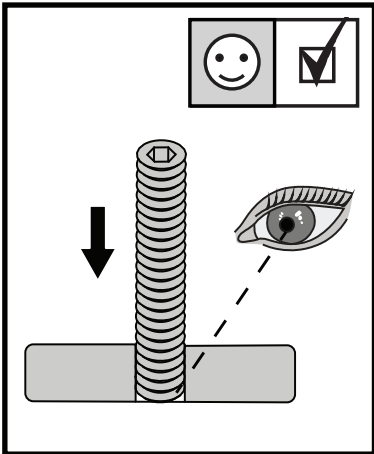

x4

27

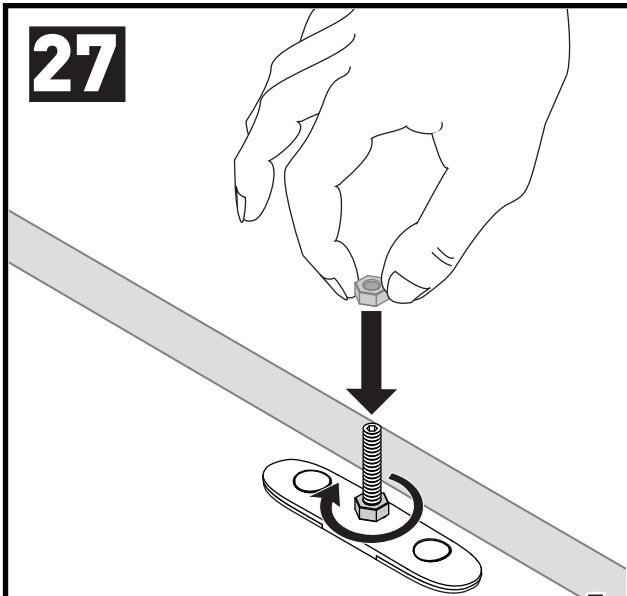

x4

28

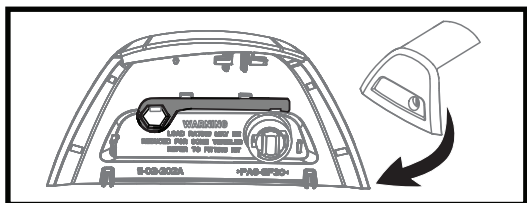

**2 Nm
(18 lb-in)**

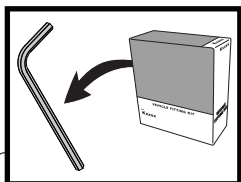

x4

29

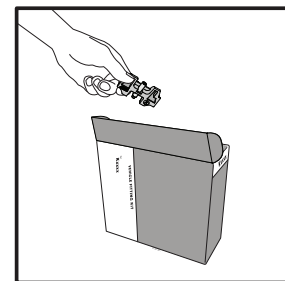
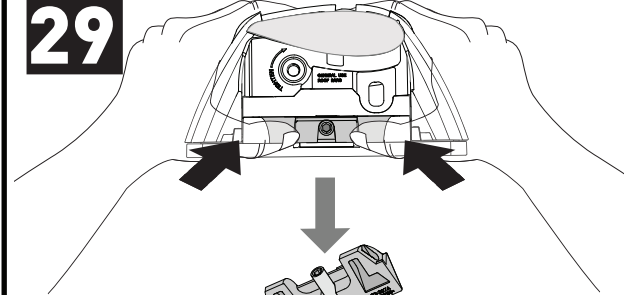

x4

30

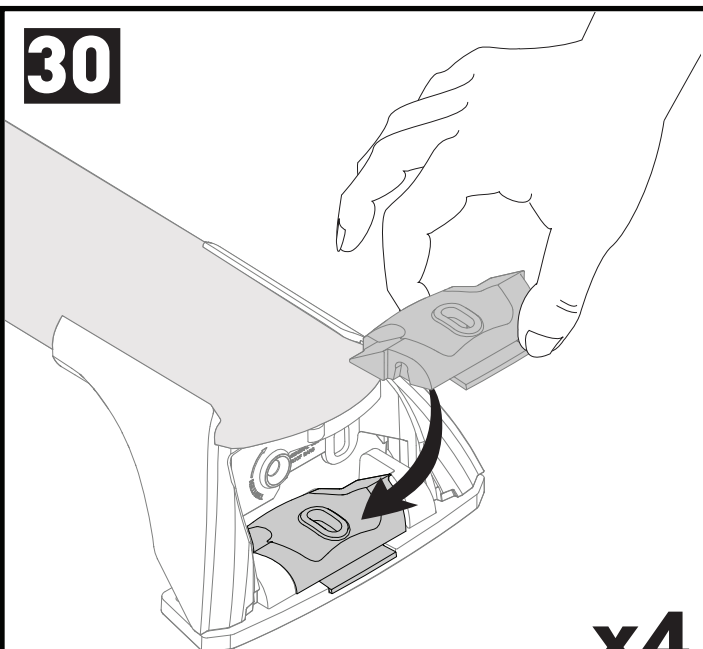

x4

31

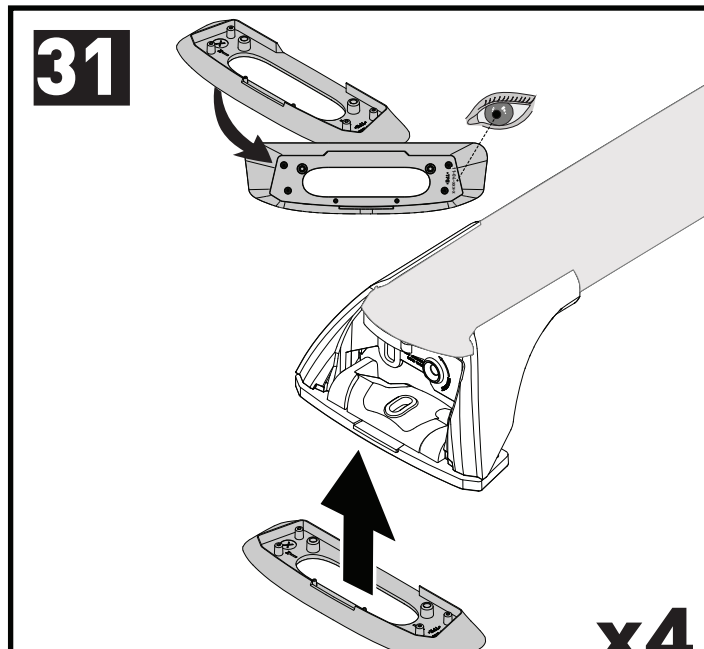

x4

32

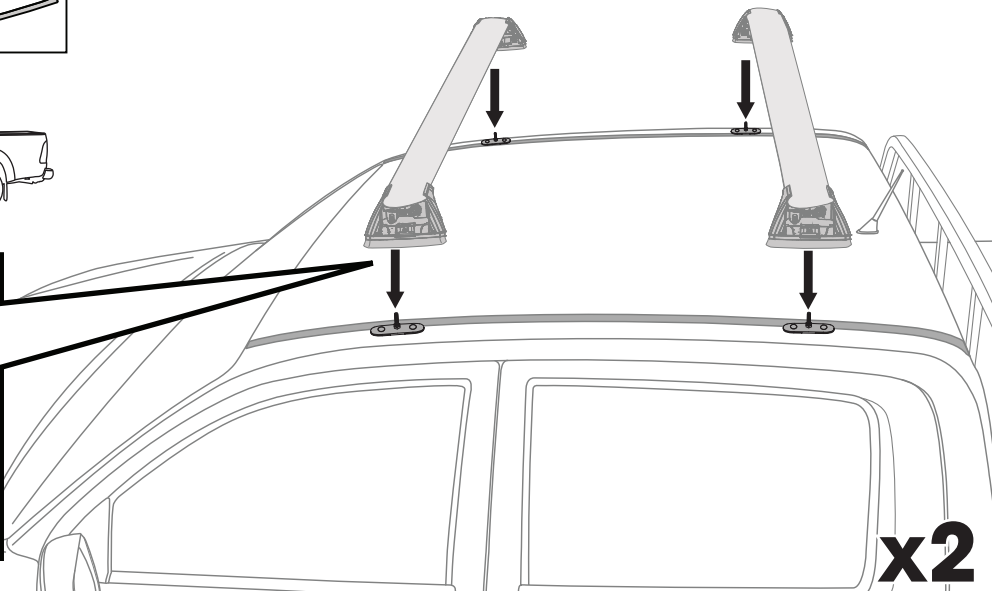
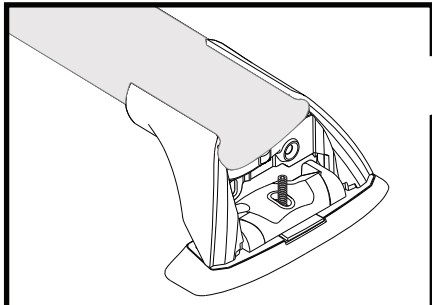
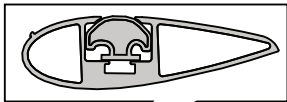

33

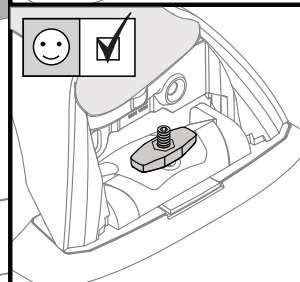
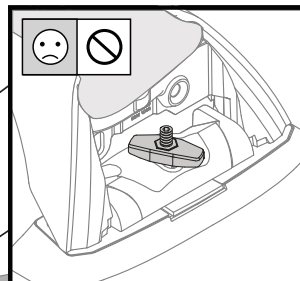
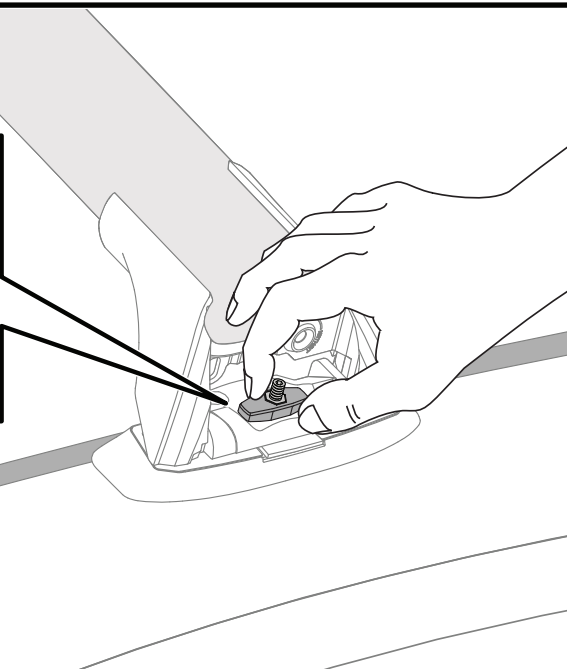
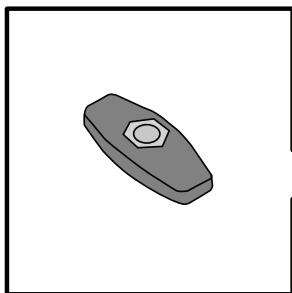

x4

34

**2 Nm
(18 lb-in)**

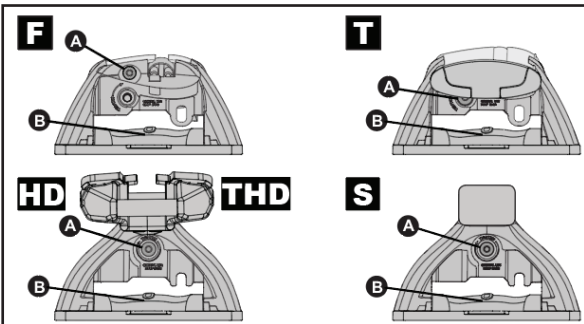
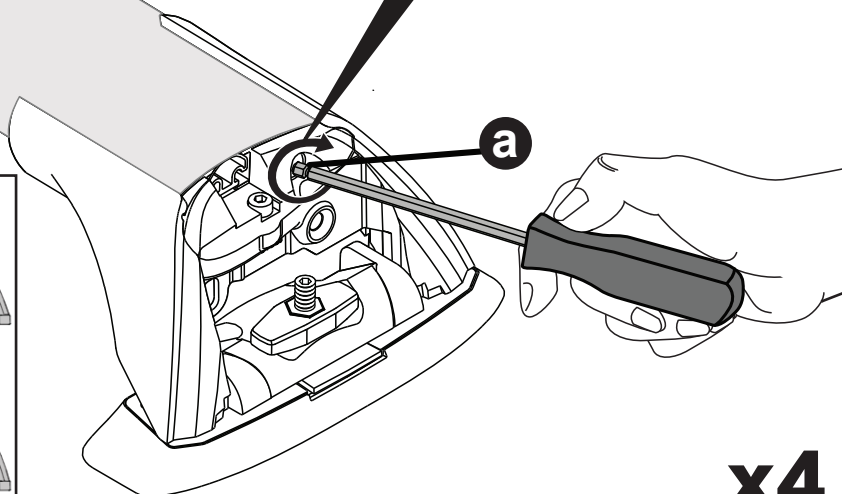

x4

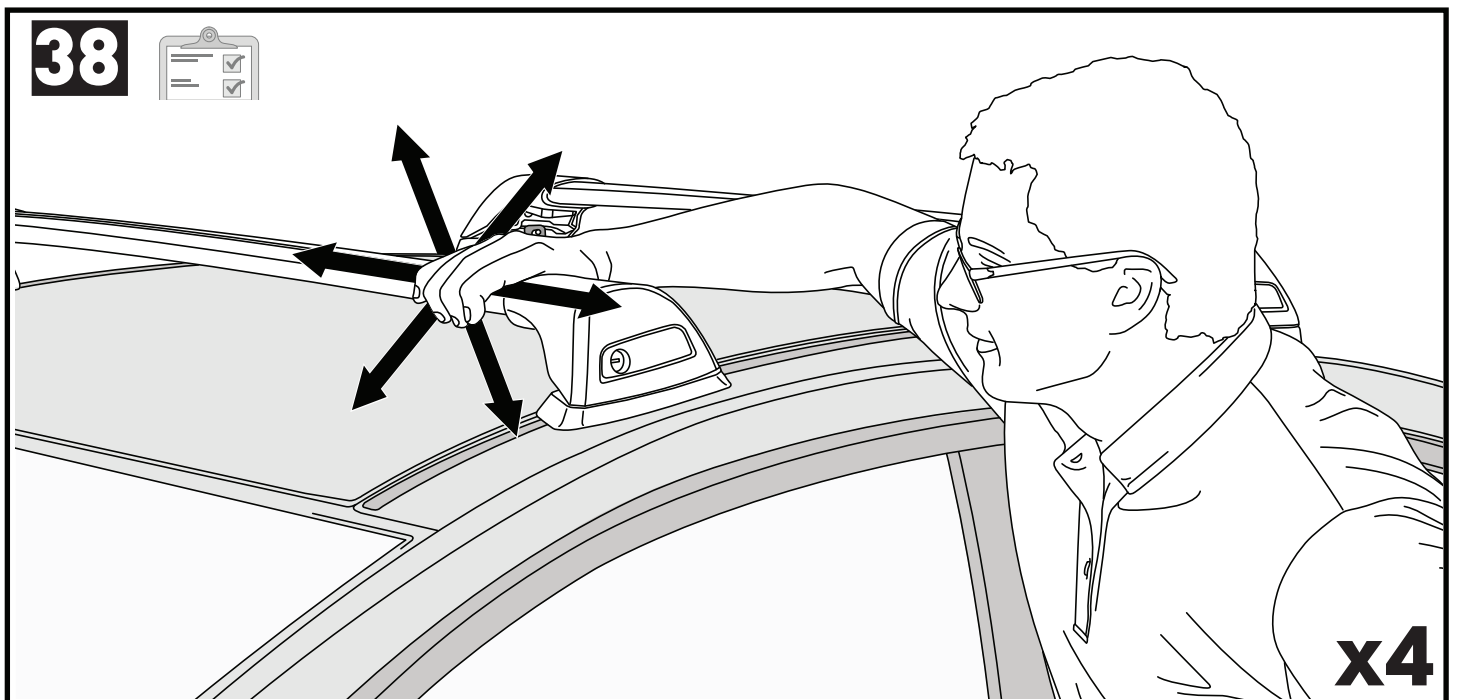
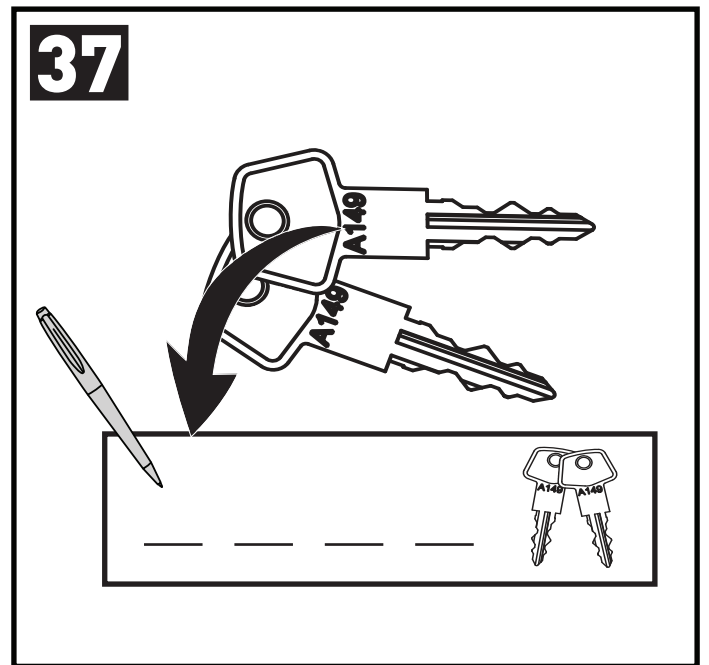
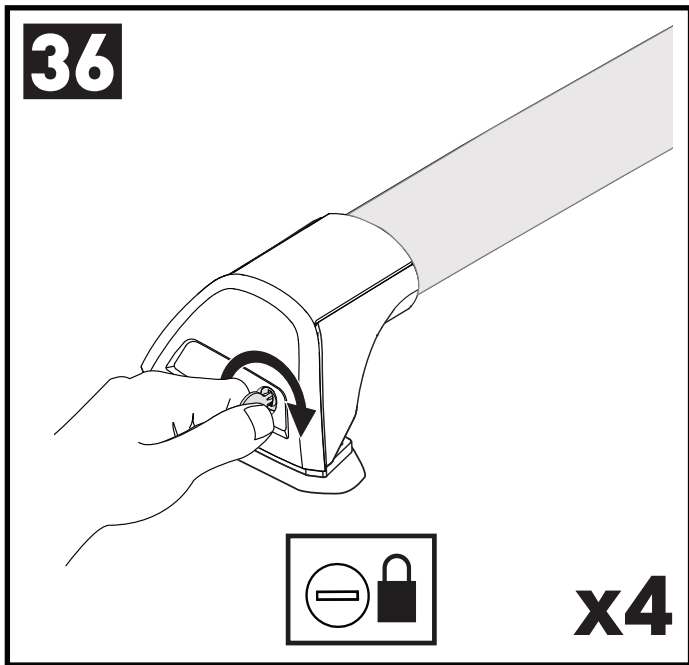
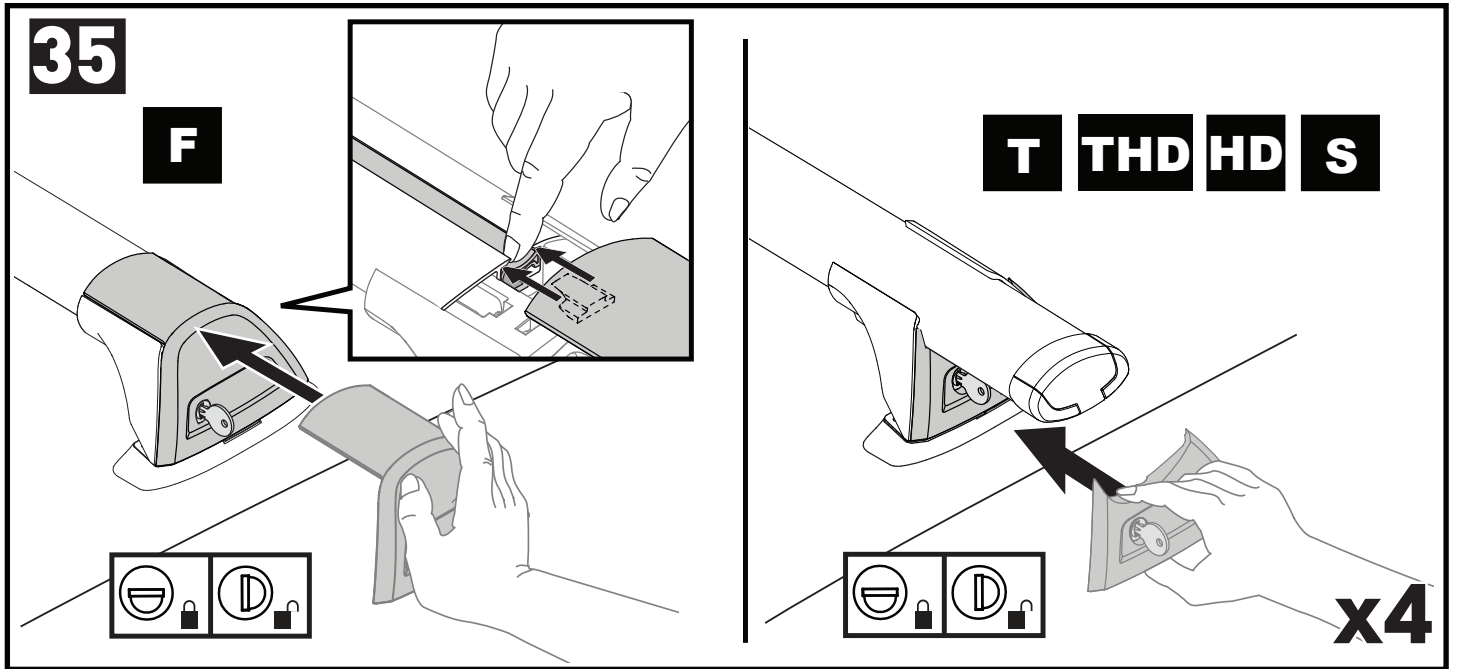

**ATTENTION • ACHTUNG • ATENCIÓN • ATTENTION • OPPMERKSOMHET • ATENÇÃO • ВНИМАНИЕ • ATTENZIONE
 UWAGA • UPOZORNĚNÍ • UPOZORNENIE • LET OP • UPPMÄRKSAMHET • ОПМÆRКСОМНED • УБАГА • HUOMIO**

- EN** Please read safety and warranty booklet included with this product prior to use. For more information visit your local dealer.
- DE** Bitte lesen und beachten Sie die beiliegende Montageanleitung, Sicherheitshinweise und Garantiebedingungen bevor Sie das Produkt montieren/benutzen. Für weitere Informationen kontaktieren Sie bitte Ihnen Händler.
- ES** Por favor, lea folleto de seguridad y garantía que se incluye con este producto antes de su uso . Para obtener más información, visite a su distribuidor local.
- FR** Veuillez lire attentivement le manuel de sécurité et de garantie avant utilisation. Pour plus d'informations, visitez votre concessionnaire local.
- NO** Vennligst les hefte om sikkerhet og garanti som er vedlagt dette produkt før det tas i bruk. For mer informasjon ta kontakt med din forhandler.
- PT** Por favor leia o manual de segurança e garantia incluído, antes de utilizar o produto. Para mais informações visite o seu revendedor local.
- RU** Пожалуйста, ознакомьтесь с инструкцией перед тем, как использовать товар. Для получения более подробной информации обратитесь к местному дилеру.
- IT** Si prega di leggere il libretto di sicurezza e garanzia incluso nel prodotto prima dell'uso. Per maggiori informazioni visita il rivenditore locale.
- PL** Proszę zapoznać się z warunkami gwarancji i bezpieczeństwa przed użyciem produktu. W celu uzyskania dodatkowych informacji proszę kontaktować się z najbliższym autoryzowanym punktem sprzedaży.
- CS** Před použitím si prosím přečtete přiložené informace o bezpečnosti a záručních podmínkách. Pro více informací navštivte nejbližšího dealera.
- SK** Pred použitím si prosím prečítajte priložené informácie o bezpečnosti a záručných podmienkach. Pre viac informácií navštívte najbližšieho dйлера.
- NL** A.U.B. bijgesloten garantie- en veiligheidsinstructies grondig lezen voor gebruik van dit product. Voor meer informatie graag contact opnemen met uw dealer.
- SV** Var snäll och läs igenom säkerhets- och garantihäftet som medföljer produkten före användning. För mer information besök din lokala återförsäljare.
- DK** Læs venligst sikkerheds- og garantibogsholderen, der følger med dette produkt, inden brug. For mere information besøg din lokale forhandler.
- UA** Будь ласка, ознайомтеся з бронею безпеки та гарантії, включені до цього продукту перед використанням. Для отримання додаткової інформації відвідайте місцевого дйлера.
- FI** Lue tämän tuotteen mukana toimitetut turvallisuus- ja takuu huoltopalvelut ennen käyttöä. Lisätietoja saat paikalliselta jälleenmyyjältä.

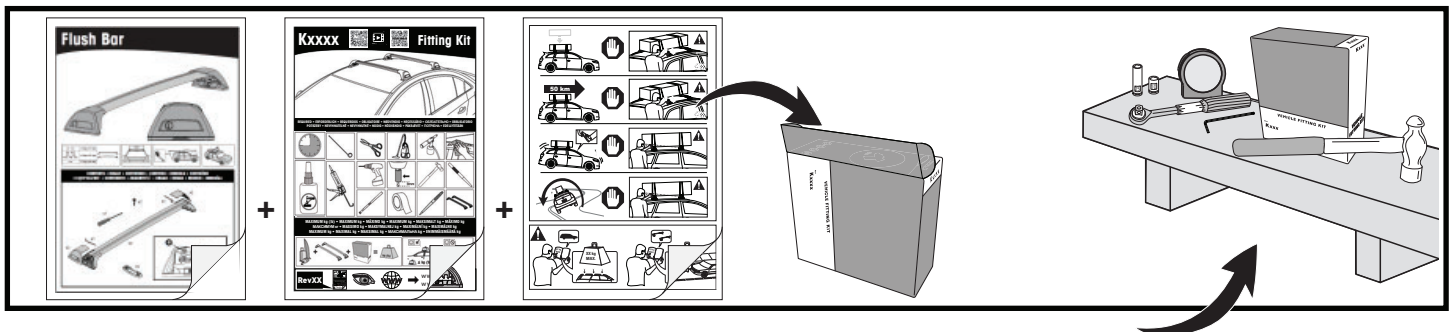

ALL CONTENT SUBJECT TO YAKIMA AUSTRALIA PTY LTD COPYRIGHT © 2016

Yakima Australia Pty Ltd
 17 Hinkler Court, Brendale
 QLD 4500, Australia
 1800 143 548
 www.prorack.com.au
 www.yakima.com.au

Yakima Products, Inc.
 4101 Kruse Way
 Lake Oswego, OR. 97035 USA
 888 925 4621
 www.yakima.com

WORKS WITH: